

DEPARTMENT OF PUBLIC SERVICE



ELECTRIC SERVICE POLICY MANUAL

2020



**A Reference Guide for
Planning and
Designing Electrical
Systems to be Served By
City of Alachua.**

- ◆ **Architects**
- ◆ **Contractors**
- ◆ **Customers**
- ◆ **Developers**
- ◆ **Electricians**
- ◆ **Engineers**

**ELECTRIC SERVICE POLICY MANUAL
CITY OF ALACHUA, FLORIDA
TABLE OF CONTENTS**

INTRODUCTION AND CONTACT INFORMATION 5

1.0 GENERAL SERVICE INFORMATION 7

 1.1 Service Type and Availability 7

 1.2 Service Quality..... 8

 1.3 Point Of Service and Use Of Service..... 8

 1.4 System Alterations and Additions..... 9

 1.5 Safety, Code, Compliance, and Inspections..... 9

 1.6 Easements and Access to Property..... 10

 1.7 Discontinuance of Service 11

 1.8 Typical Drawings..... 11

2.0 GENERAL CUSTOMER INFORMATION 24

 2.1 Applying for Service, Deposits 24

 2.2 Required Information..... 24

 2.3 Customer Equipment 24

 2.4 Temporary Service..... 25

 2.5 Customer Alterations or Additions 25

 2.6 Standby and Parallel Generation..... 25

3.0 DESIGN REQUIREMENTS 26

 3.1 Temporary Service..... 26

 3.2 Overhead Service 26

 3.3 Underground Service 27

 3.4 Service in New Development 28

 3.5 Responsibility for Furnishing and Installing Underground Infrastructure..... 30

4.0 METERING 37

 4.1 Type 37

 4.2 Materials 37

 4.3 Meter Location..... 38

 4.4 Primary Metering..... 38

 4.5 Current Transformer (Ct) Metering 39

 4.6 Multiple Installations..... 39

4.7	Mobile Home Metering.....	41
4.8	Meter Accuracy Testing.....	42
5.0	LIGHTING SERVICES	42
5.1	Public Lighting.....	42
5.2	Street Lighting for New Developments	42
6.0	DEFINITIONS	44
7.0	EXHIBITS	Error! Bookmark not defined.

INTRODUCTION AND CONTACT INFORMATION

Our goal is to provide every Customer with safe, reliable and competitively priced electricity. Achieving this goal means working closely with each Customer to build efficient electrical facilities. The City of Alachua Electric Service Policy has been written to inform you about our requirements for installing, maintaining and replacing electric service and metering equipment.

The City of Alachua Electric Service Policy is for our Customers who may be planning, designing and building facilities requiring electric service. This guide is also for those Customers who are planning changes to their existing electric service. We encourage you to familiarize yourself with the service policy contents. When you follow this guide, we are better able to provide the best possible service.

Every effort has been made to ensure that the requirements contained in the City of Alachua Electric Service Policy are up-to-date. However, your needs, changing codes and technology may require us to revise this policy.

Our staff stands ready to provide any additional information you may need. A calling list is provided for your convenience. **We welcome your comments and suggestions. Please address them to:**

City of Alachua
Electric System Planner
P. O. Box 9
Alachua, Florida 32616-0009

CITY OF ALACHUA CALLING GUIDE

New Service (386) 418-6100

Contact the City of Alachua Building Department for general assistance and information on new services, including information about electric utility services, applications, fees and related concerns.

Anthony Lindsey, Electric System Planner, Electric Department (386) 518-5832

Contact the Electric System Planner, Electric Department for information on the availability of service, service voltage characteristics and construction planning and for assistance with extensions of service and additions, information on specific electric metering requirements, revenue meters, meter sockets and related equipment when it is furnished by the City of Alachua in accordance with this policy. This department also assists Customers in determining the acceptability of Customer furnished electric metering equipment or modifications to existing services.

Contact the Electric System Planner for information on the following: construction scheduling; for information on required inspections of Customer installed utility facilities; and inquires about new service installation.

City of Alachua, Building Inspection Department (386) 418-6100

Electric Outage Reporting Center (386) 418-6185

Contact for information on building permits and inspections, within the City of Alachua.

Alachua County, Building Department (352) 374-5243

Contact for information on building permits and inspections within the unincorporated area of Alachua County.

ELECTRIC SERVICE POLICY MANUAL CITY OF ALACHUA, FLORIDA

1.0 GENERAL SERVICE INFORMATION

1.1 SERVICE TYPE AND AVAILABILITY

- A. The City of Alachua Electric Utility (City) provides information about the availability of electrical service for a specific location. The City will confirm the availability of service, point of delivery and service characteristics of all services. To assure prompt service, Customers are encouraged to contact the City well before the required service start date.
- B. Service voltage and characteristics offered will be determined by the City based on the character of the Customer's load and the type of City primary and secondary distribution system in the area. The following table will serve as a guide in determining the type of service(s) for which the Customer may qualify. Special service requests will be considered case-by-case.

Service Voltage Description *	Minimum Demand	Maximum Service Size
120/240V 1-ph 3-wire	None	
Overhead		400 Amps
Underground from pole		400 Amps
1-ph pad-mount transformer		400 Amps
120/240V 3-ph 4-wire delta	1-7.5 Hp or 30 kW	
Overhead		800 Amps
Underground from pole		800 Amps
Two 1-ph circuits pad-mount transformer		600 Amps

Service Voltage Description *	Minimum Demand	Maximum Service Size
120/208V 3-ph 4-wire Wye	1-7.5 Hp or 30 kW	
Overhead		800 Amps
Underground from pole		800 Amps
3-ph pad-mount transformer		1600 Amps
277/480V 3-ph 4-wire Wye	100 kW	
Overhead		1000 Amps
Underground from pole		1000 Amps
3-ph pad-mount transformer		2000 Amps

* All voltages are nominal and are subject to variation within parameters established by the Florida Public Service Commission.

1.2 SERVICE QUALITY

- A. The City strives to give its Customers the highest quality service available. However, normal system operations and unavoidable system disturbances may impact certain types of sensitive equipment, most notably computers and solid-state motor controls.
- B. The City will strive to provide service as constant as is reasonably practical. However, the City does not guarantee its service will be free from temporary interruption. Temporary interruption of service will not constitute a breach in City service obligations, and neither the City nor the Customer shall be liable to the other for damages resulting from any temporary interruption.
 - 1. In the event of interruption of service, service will be restored as soon as reasonably practical. In the event conditions on the Customer's premises cause the interruption, the City will permit a reasonable amount of time for the Customer's condition to be corrected. The City reserves the right to disconnect service until that time in order to preserve the safety and reliability of the distribution system.
 - 2. It is the Customer's responsibility to protect its motors and other electrical equipment from the effects of momentary or sustained disruptions in service, fluctuations in voltage, excessive current (load and fault currents), single phasing (loss of power in one or more phase conductors), and phase reversal.

1.3 POINT OF SERVICE AND USE OF SERVICE

- A. The City will provide only one service drop and one meter on a structure when that structure serves only one entity, be that entity a person, a family, a business, an organization, or any other entity of any kind. For a building containing multiple

entities, the City will provide electrical service at one point on the structure with multiple meters, one for each entity.

1. The City will designate the point of service location for each electrical service provided and for each existing electrical service where the service entrance is being modified. The Customer shall contact the City prior to installation of Customer's wiring for designation of the service location.
 2. The characteristics of the Customer's electrical load shall be such that load balance, motor starting, power factor, generation of harmonics, or any other factor does not adversely affect the operation of the City's system or the quality of service to other City Customers. As a general design guideline, Customer shall connect and balance wiring loads so that the difference in current (amperes) between phases will be 15% or less, as measured from the most heavily loaded phase to the least loaded phase.
- B. All electricity purchased from the City is for Customer use only and is not available for resale.

1.4 SYSTEM ALTERATIONS AND ADDITIONS

- A. The City will construct any required extension, improvement or modification of its distribution facilities that are required to render service to a Customer, in accordance with adopted City policies.
- B. Any proposed construction in conflict with the City's existing electric facilities shall be identified well in advance to ensure an orderly adjustment or relocation of the facilities in question.
- C. Service conductors, connections and all other components of the City's distribution system shall be installed, modified, or removed only by qualified employees of the City or its authorized agent(s).
- D. The cost of Customer-initiated relocations, modifications, removals or conversions of overhead to underground utility facilities will be charged to the Customer. All costs shall be paid in advance of any work.

1.5 SAFETY, CODE, COMPLIANCE, AND INSPECTIONS

- A. Customers shall install all wiring and electrical equipment according to National Electrical Code (NEC), National Electrical Safety Code (NESC), and all other guidelines associated with the City Building Department or other applicable local inspection authority.
 1. If any installation, addition, or alteration requiring wiring permits is made by the Customer, the City will not connect or alter service until approval of the installation is made by all local Inspection authorities. The City's electric personnel have no obligation to determine whether a Customer's wiring, equipment or general electrical installation is safe for use; however, the City will make a field visit to check the Customer's service entrance facilities for compliance with this manual. If the electrical system is deemed unsafe or not in compliance, the City will refuse to connect service.

- B. The Customer shall furnish, install and maintain a permanent and effective grounding system as part of the service installation. A maximum resistance to remote earth of 15 ohms is recommended, as is the application of transient voltage surge suppression devices. The City provides a grounded neutral conductor in all service cables. The City will not be responsible for any equipment damage or loss resulting from electrical discontinuity or diminished effectiveness of the distribution system neutral or service neutral conductor, if the Customer's service entrance is not properly grounded.
 - 1. The Customer is responsible for retaining the services of a qualified consultant when designing service entrance equipment for available fault current. A table of Available Fault Current and minimum percent impedance (%Z) of transformers is included in this Manual as Exhibit 7.1. Contact the City for availability of other sizes or additional information.

1.6 EASEMENTS AND ACCESS TO PROPERTY

- A. The City shall at all times have access to City facilities on Customer's property for the purpose of installing, maintaining, inspecting, repairing, removing or disconnecting its electric equipment and facilities, and for meter reading. The Customer shall grant or cause to be granted to the City without cost to the City all rights, easements, permits, and privileges that are necessary for the rendering of services to the Customer before service will be granted to the Customer.
 - 1. Necessary utility easement will be determined by the City and will be described or shown clearly on documents provided to the Customer.
 - a. The Customer shall avoid encroachment or interference with operation and maintenance of the City's facilities within the easement area. The Customer shall also grant permission for the City to trim or remove any trees or other vegetation upon land adjacent to but outside the easement area that endangers or interferes with safe and efficient operation of the electric facility.
- B. The Customer shall take action to reasonably and diligently protect City facilities on the Customer's property.
- C. Prior to planting trees or shrubs, or for any excavation in or near the electric easement area or other public right-of-way, the Customer shall contact 811 Sunshine for assistance in locating facilities of the utilities operating within the City.
- D. Under no circumstance should a Customer attempt or allow others to attempt to remove or trim trees and/ or brush or remove other materials that are in contact with or in close proximity to overhead power lines. Instead, the City shall be notified.
- E. To allow room for construction and maintenance, a minimum of ten (10) feet of clearance in front of doors and four (4) feet of clearance on all other sides of pad mounted equipment is required. See drawing on page 18. For overhead and underground facility clearances, see drawings on pages 19 and 20.

1.7 DISCONTINUANCE OF SERVICE

- A. The City reserves the right to refuse or discontinue service for any of the following reasons. Reasons for refusal of applications for electric service may include:
 - 1. Unsafe or inadequate facilities available to provide service requested by the applicant.
 - 2. Service requirements for equipment requested will unfavorably affect other Customers.
 - 3. The service requested is not compatible with City distribution voltage.
 - 4. Failure or refusal to provide all required fees, deposits, permits, and certificates of inspection.
 - 5. Failure to provide Easement.
 - 6. For any emergency situation, i.e. fire or electrical problem.
- B. Service may be discontinued after a diligent attempt by the City to obtain Customer compliance and will include at least five working days written notice to the Customer for the following reasons:
 - 1. Non-compliance with federal, state or local law or ordinance governing electrical service.
 - 2. Failure or refusal to provide adequate space for City facilities and equipment necessary to provide electrical service.
 - 3. Non-compliance with the policies of this manual.
 - 4. For neglect or refusal to provide safe, reasonable easement access.
 - 5. Customer load characteristics that cause load imbalance, voltage fluctuation, poor power factor, excessive harmonics, or any other factor that adversely affects the operation of the City's system or the quality of service to other Customers.
- C. The City may discontinue or refuse service without notice for the following reasons.
 - 1. For non-payment of bills (information contained on the bill serves as notice).
 - 2. For conditions known to the City to be hazardous.
 - 3. Tampering with meters or other City facilities or equipment.
 - 4. For the unauthorized or fraudulent use of electric service.

1.8 TYPICAL DRAWINGS

TYPICAL OVERHEAD INSTALLATION - FOR RESTORATION ONLY - NO NEW OVERHEAD SERVICE INSTALLATION

NOTES:

- 1) Conductors shall extend 3 ft. (min.) beyond weatherhead.
- 2) Customer shall furnish and install attachment hardware.
- 3) Service drop minimum clearance (above finished grade):
 - 16' - above residential driveways,
 - 18' - above public driveways, alleys and roads
- 4) Three-phase sockets furnished and installed by Customer.

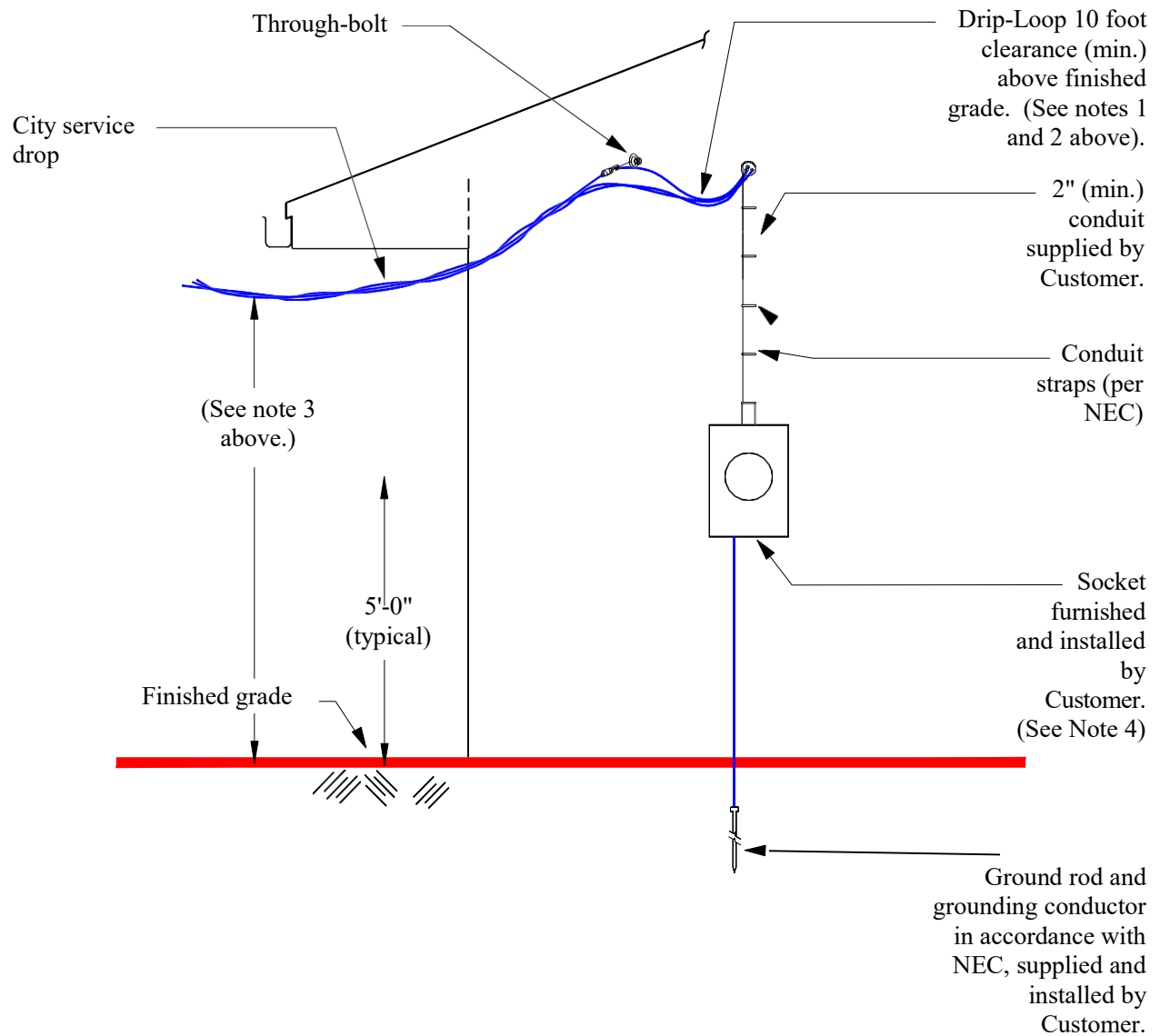

TYPICAL SERVICE MAST INSTALLATION - FOR RESTORATION ONLY - NO NEW SERVICE MAST INSTALLATION

- NOTES: 1) Any service mast exceeding 3 feet in height above the roof or last means of support shall be adequately guyed.
 2) Conductors shall extend 3 feet (min.) beyond weatherhead.
 3) Three-phase sockets furnished by and installed by Customer.

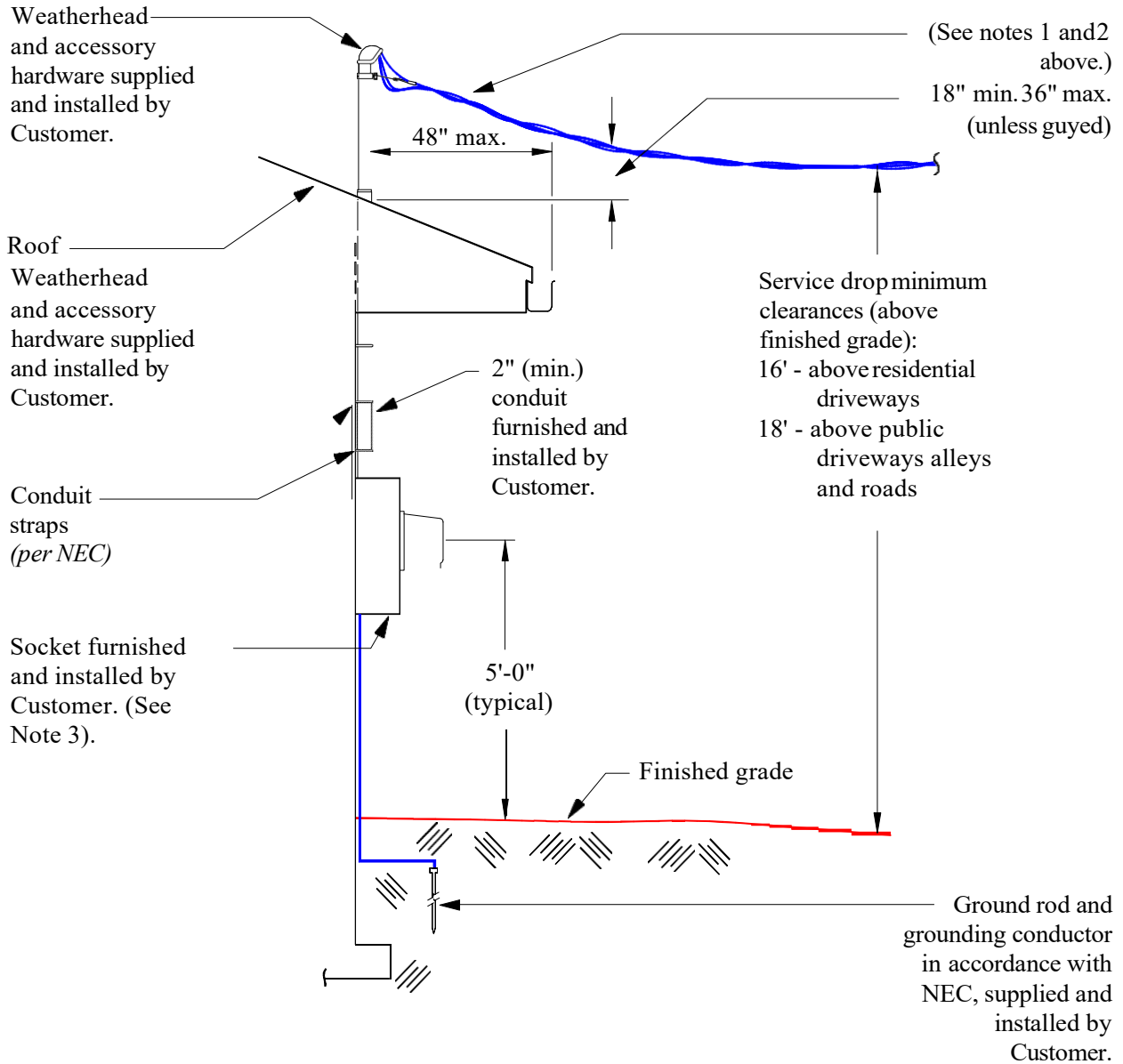

TYPICAL RESIDENTIAL SINGLE FAMILY DETACHED UNDERGROUND INSTALLATION

NOTES:

- 1) Customer shall locate load-side conduit on right side of socket, line-side conduit on the left.
- 2) Customer shall furnish and install service conduit to service pedestal or transformer.

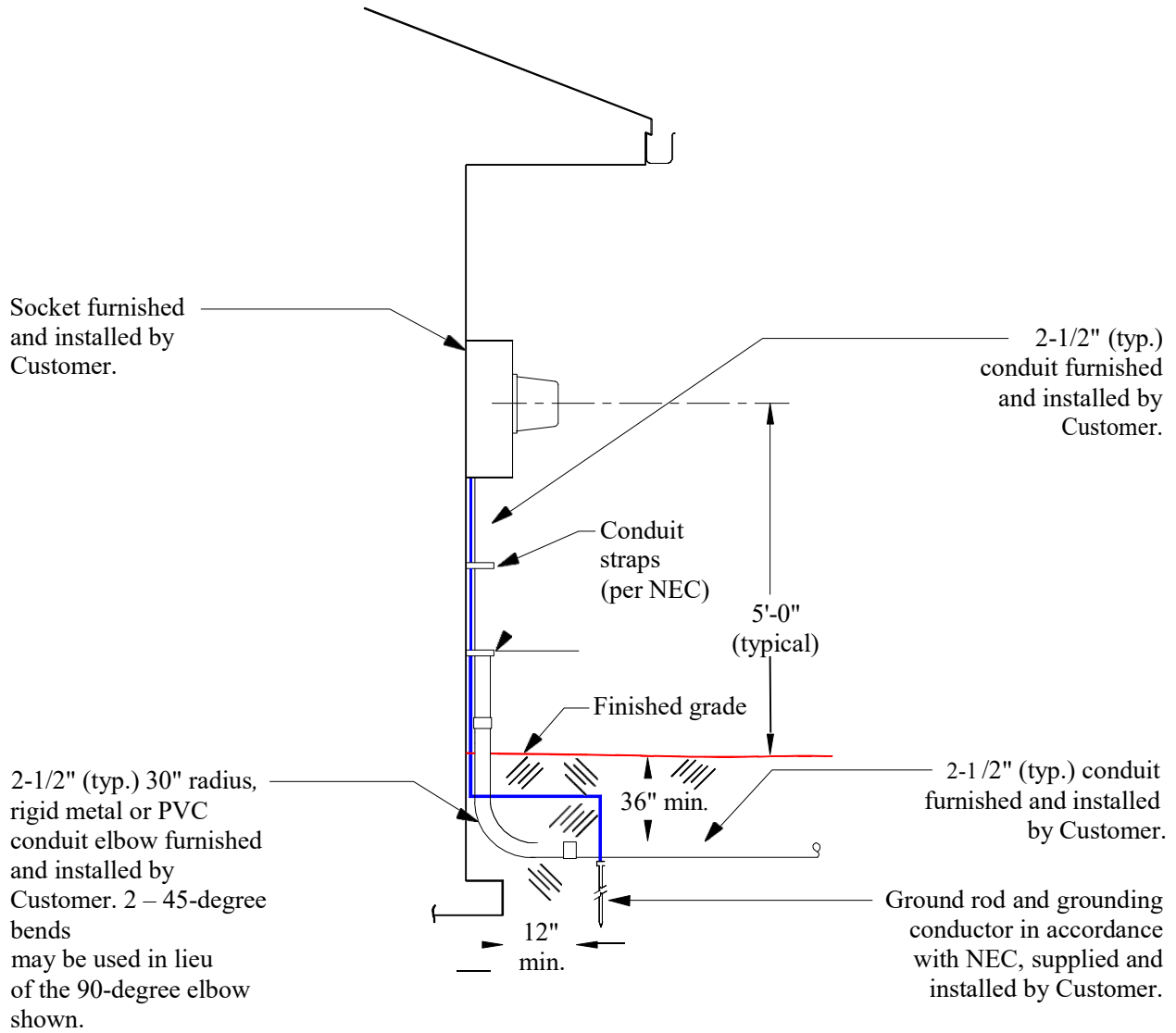

TYPICAL OVERHEAD TEMPORARY SERVICE INSTALLATION

NOTES:

- 1) Pole shall not be located in Right-of-Way.
- 2) Service drop minimum clearance (above finished grade):
 - 16' - above residential driveways,
 - 18' - above public driveways, alleys and roads

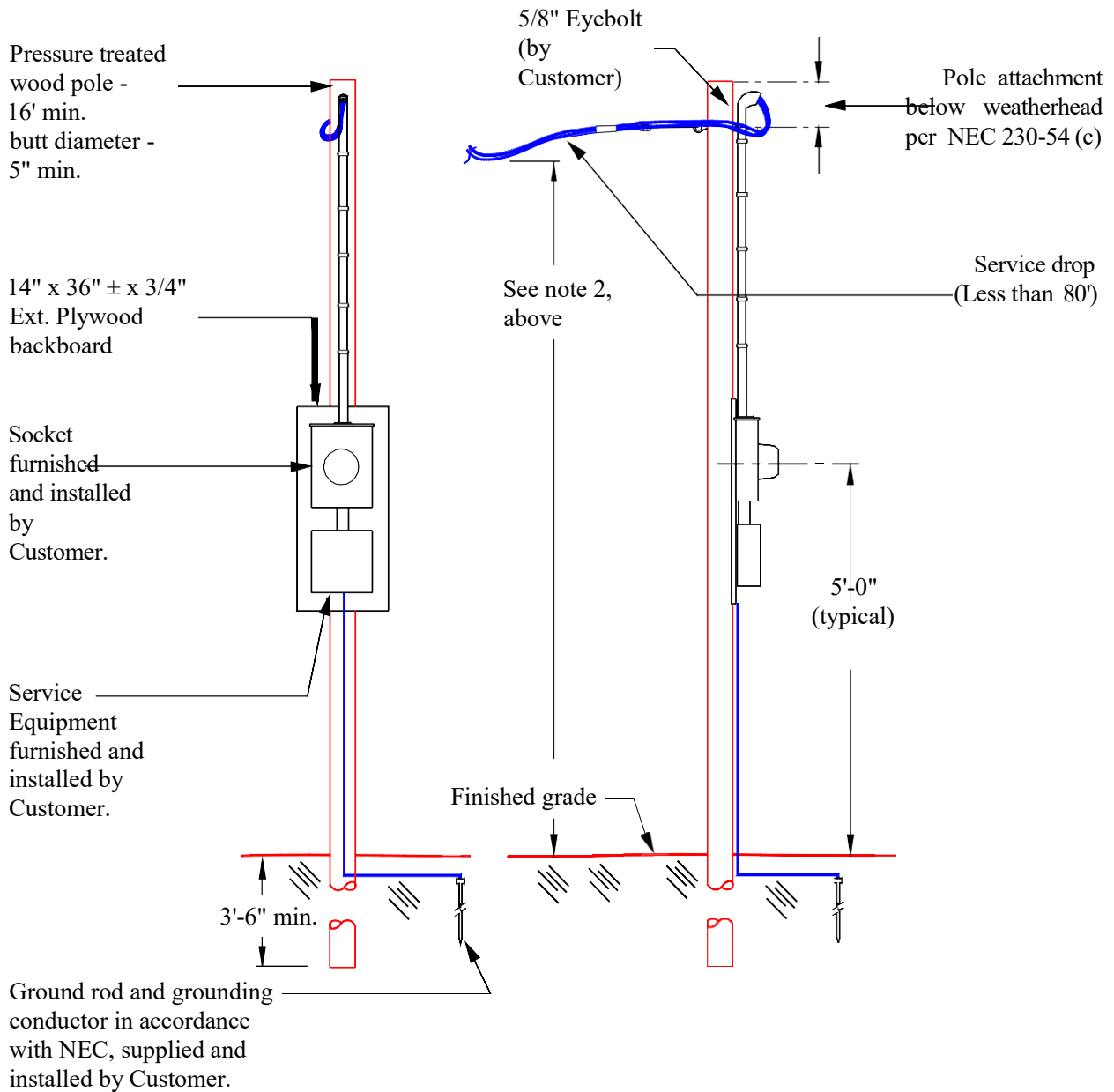

TYPICAL UNDERGROUND TEMPORARY SERVICE INSTALLATION

NOTES:

- 1) Pole shall not be located in Right-of-Way.
- 2) Mounting pole shall be pressure treated 4" x 4" x 8'-0" min.
- 3) Extend service 3'-0" above finished grade.
- 4) Underground Distribution = UD
- 5) Property Line = P/L

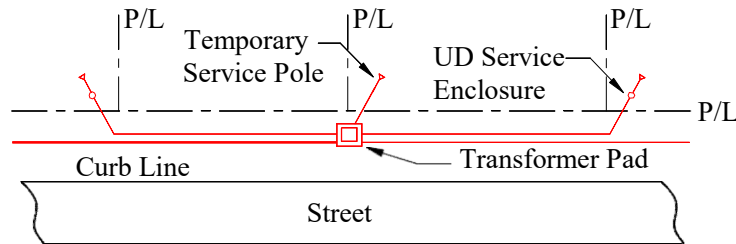
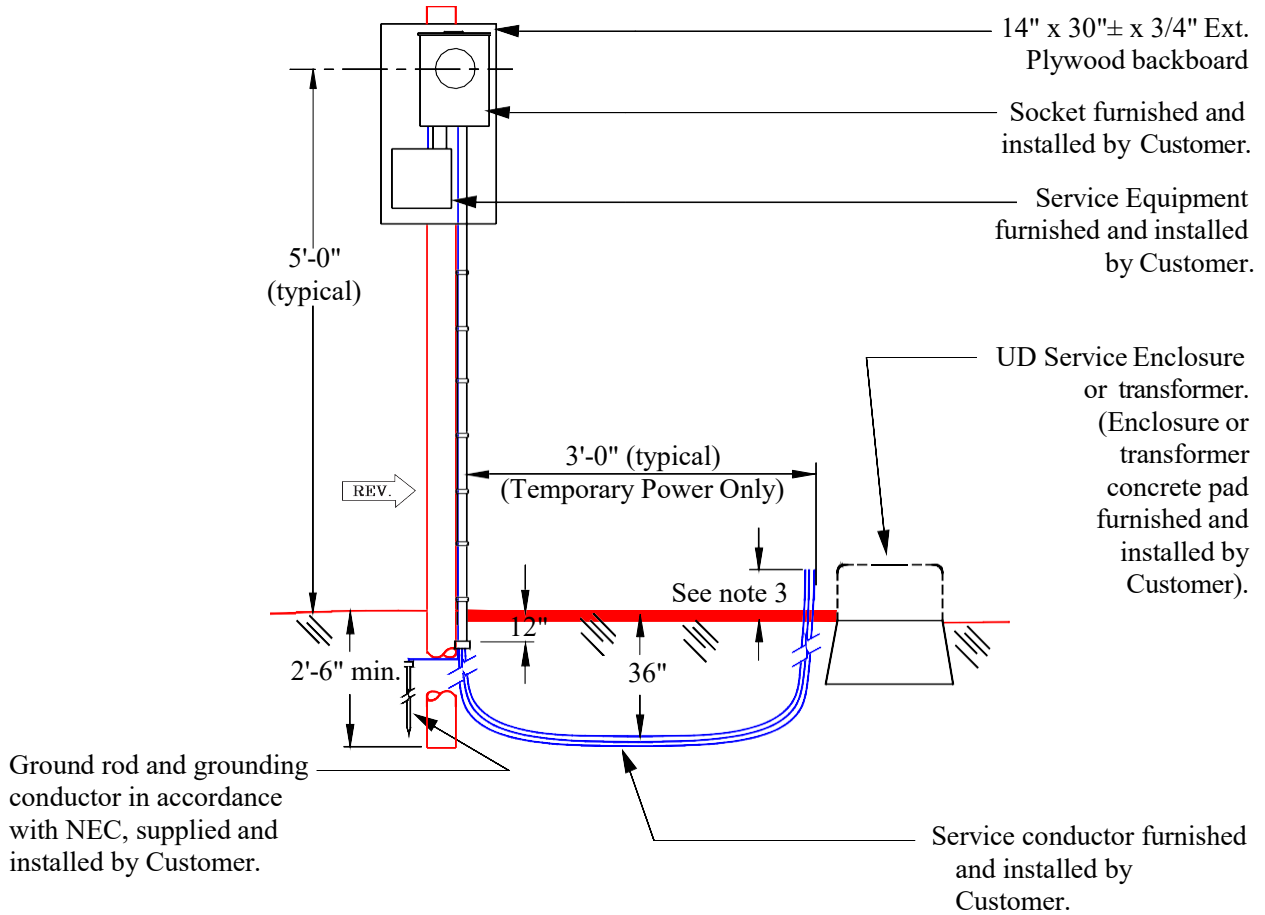

Plan view showing typical placement at temporary underground service.

SINGLE FAMILY DETACHED RESIDENTIAL SERVICE CONVERSION FROM OVERHEAD TO UNDERGROUND

NOTES:

- 1) City- approved meter socket, conduit (from meter to Service Enclosure) and Service Enclosure furnished and installed by Customer.
- 2) All riser conduit from transformer to Service Enclosure and all cable from overhead transformer to Customer meter shall be paid for by Customer and installed by City.
- 3) All connections at the transformer and underground Service Enclosure will be made by City.
- 3) Ownership of any Customer installed conduit system for a detached single family residential service will be transferred to City upon acceptance.
- 4) See page 14 for the drawing showing the dimensional details for an Underground Residential Single Family Detached installation.

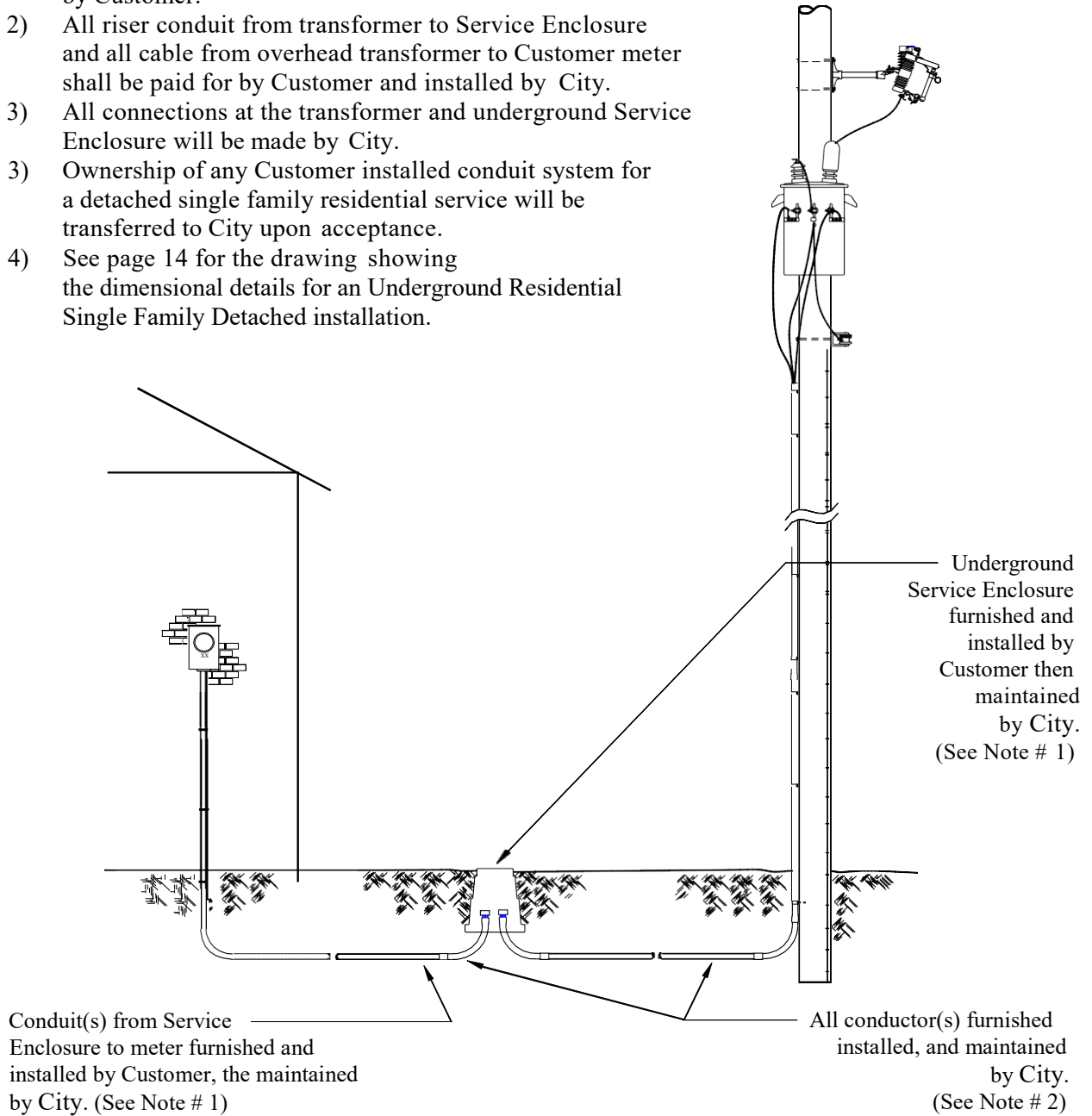

TYPICAL PAD MOUNTED EQUIPMENT CLEARANCE DETAIL

NOTE:

- 1) To allow room for construction and maintenance, a minimum of ten (10) feet of clearance in front of doors and four (4) feet of clearance on all other sides of pad mounted equipment is required. **Do not place trees, shrubs or other obstructions in this area.**

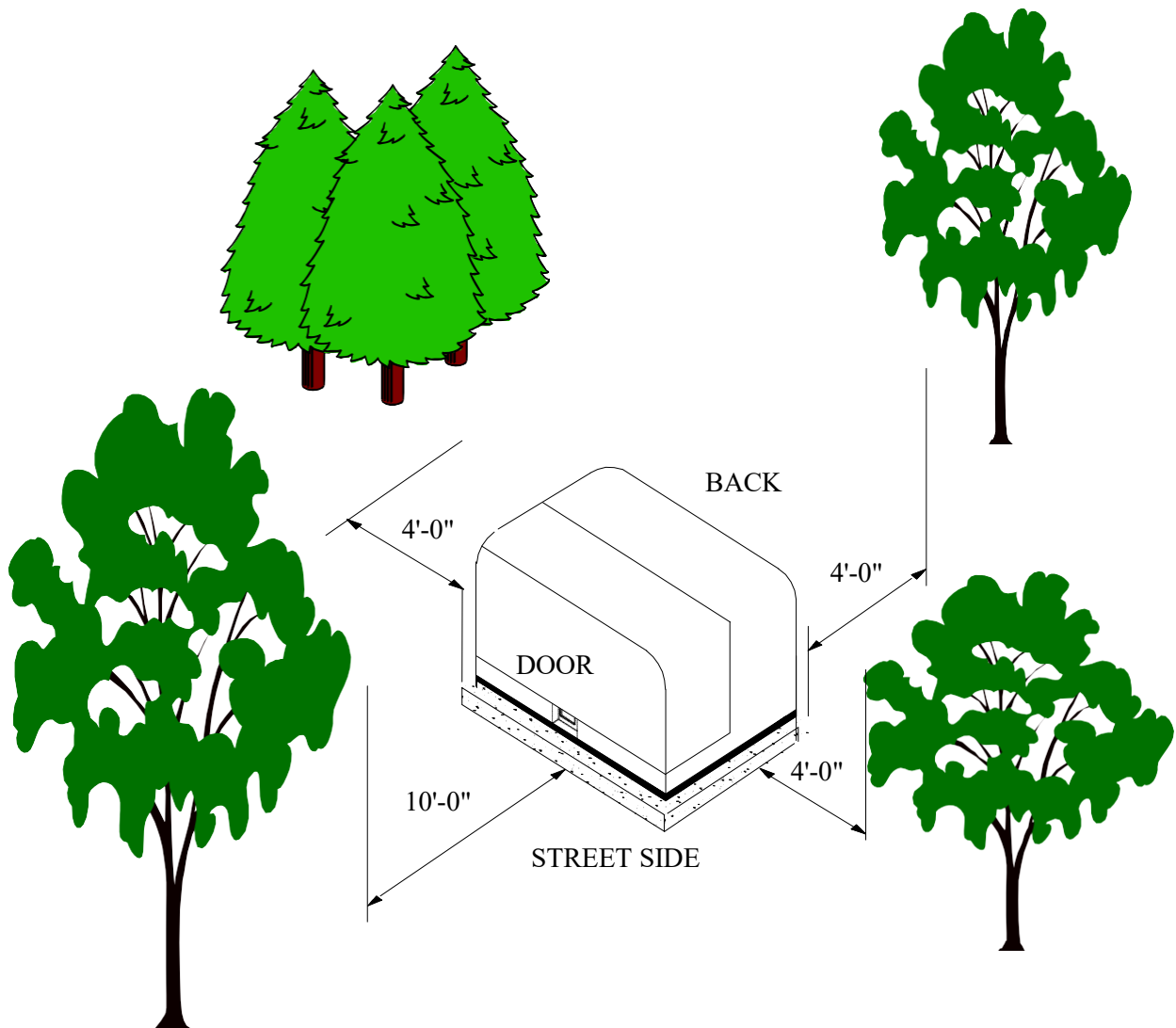

TYPICAL UNDERGROUND DISTRIBUTION (UD) UTILITY CLEARANCE DETAIL

NOTE:

- 1) To allow room for construction and maintenance, the Customer shall grant the City of Alachua a utility easement for the purpose of rendering safe and reliable service. **Do not place trees, shrubs or other obstructions in this area.**

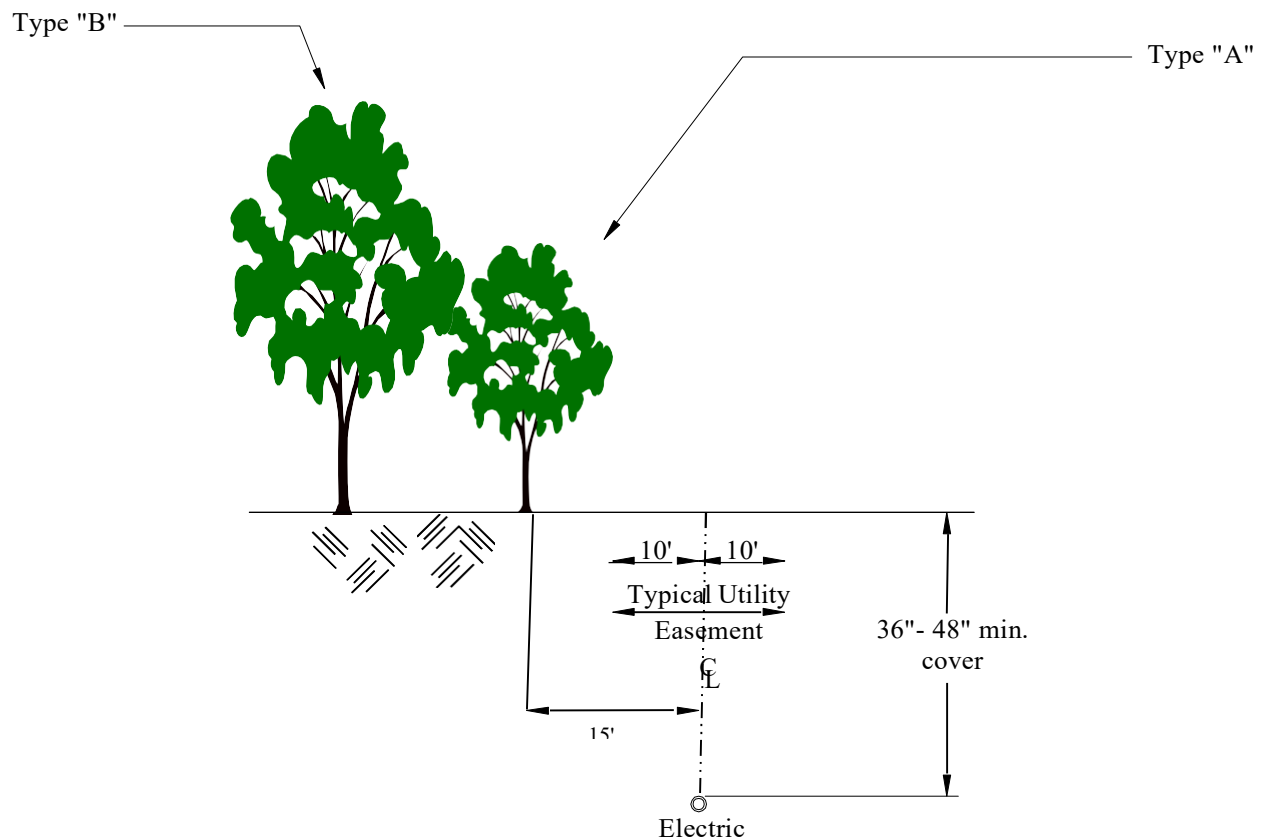

Type "A" : Crown height and spread of 30 feet or less

Type "B" : Crown height and spread of 30 to 60 feet

TYPICAL OVERHEAD UTILITY CLEARANCE DETAIL

NOTE:

- 1) To allow room for construction and maintenance, the Customer shall grant City of Alachua a utility easement for the purpose of rendering safe and reliable service. **Do not place trees, shrubs or other obstructions in this area.**

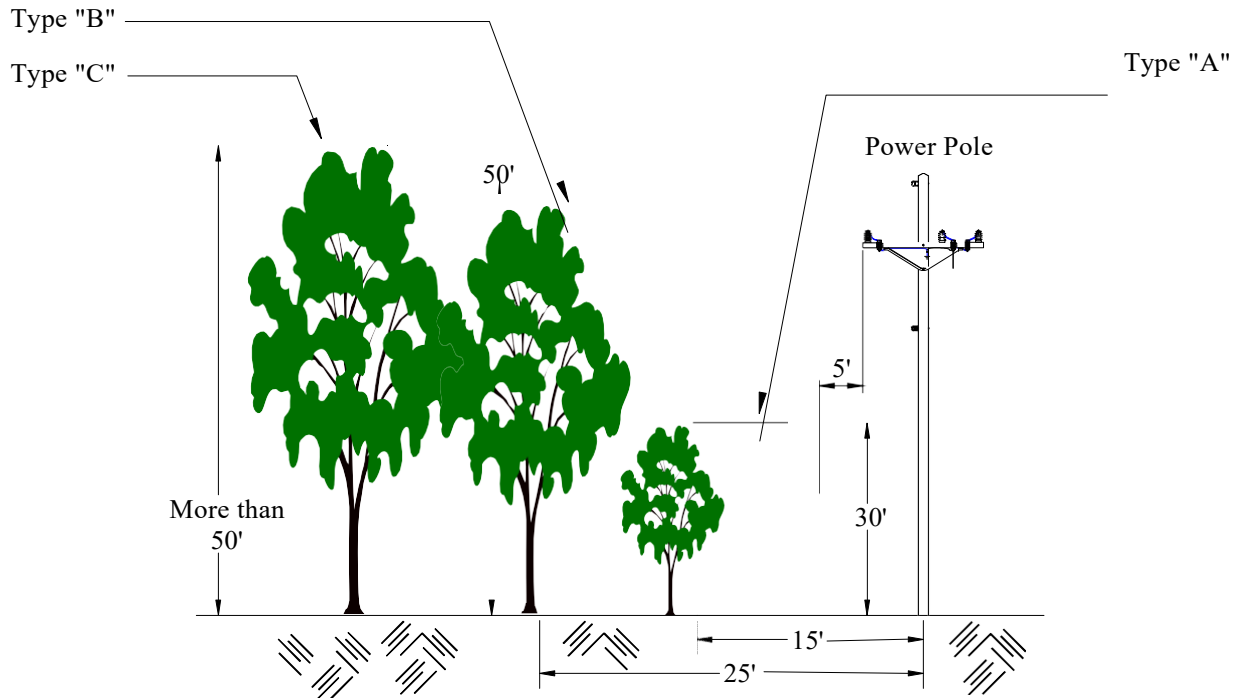

Type "A" : Crown height and spread of 30 feet or less

Type "B" : Crown height and spread of 30 to 60 feet

Type "C" : Crown height and spread over 60 feet

UNDERGROUND RESIDENTIAL SERVICE WITH AN UNDERGROUND ENCLOSURE/PEDESTAL

NOTES:

- 1) City -approved meter sockets furnished and installed by Customer.
- 2) All connections in the transformer and underground enclosures/pedestals will be made by City.
- 3) Ownership of any Customer-installed conduit system for a detached single family residential service will be transferred to City upon acceptance.
- 4) See page 14 for the drawing showing the dimensional details for an Underground Residential Single Family Detached installation.

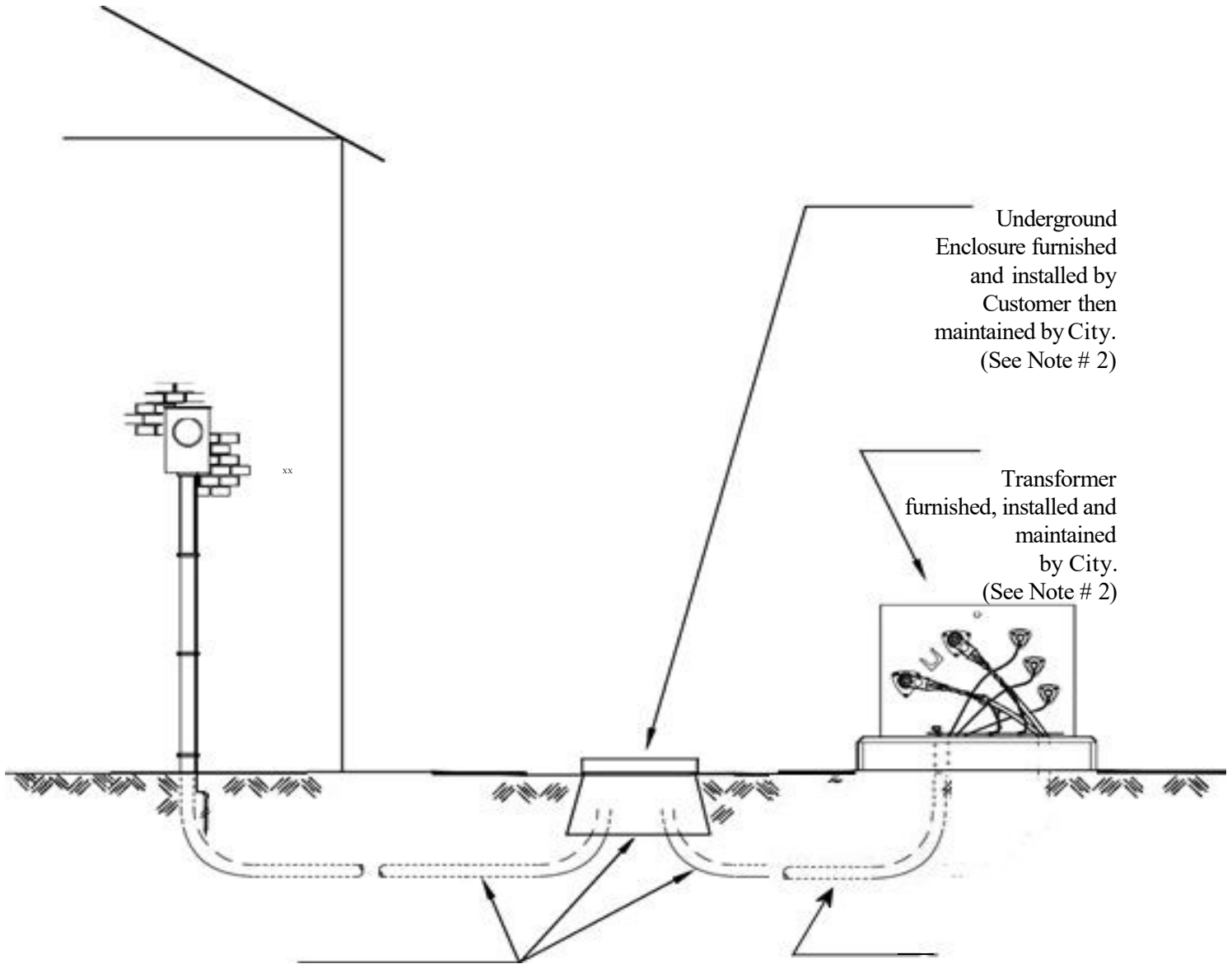

Underground Enclosure furnished and installed by Customer then maintained by City. (See Note # 2)

Transformer furnished, installed and maintained by City. (See Note # 2)

Conduit(s) and underground Enclosures / pedestals furnished and Installed by customer, then maintained by City. (See Note #3)

All conductor(s) furnished installed, and maintained by City. (See Note # 3)

UNDERGROUND NON-RESIDENTIAL SERVICE

NOTES:

- 1) City -approved meter center furnished, installed and maintained by Customer.
- 2) Meter centers with ring type design shall be supplied by Customer with screw type rings approved by City.
- 3) Line-side disconnect with overcurrent device is required.
- 4) Load-side service disconnects and overcurrent devices are required.
- 5) All conductors and conduits will be furnished, installed and maintained by Customer.
- 6) All connections in the transformer will be made by City.

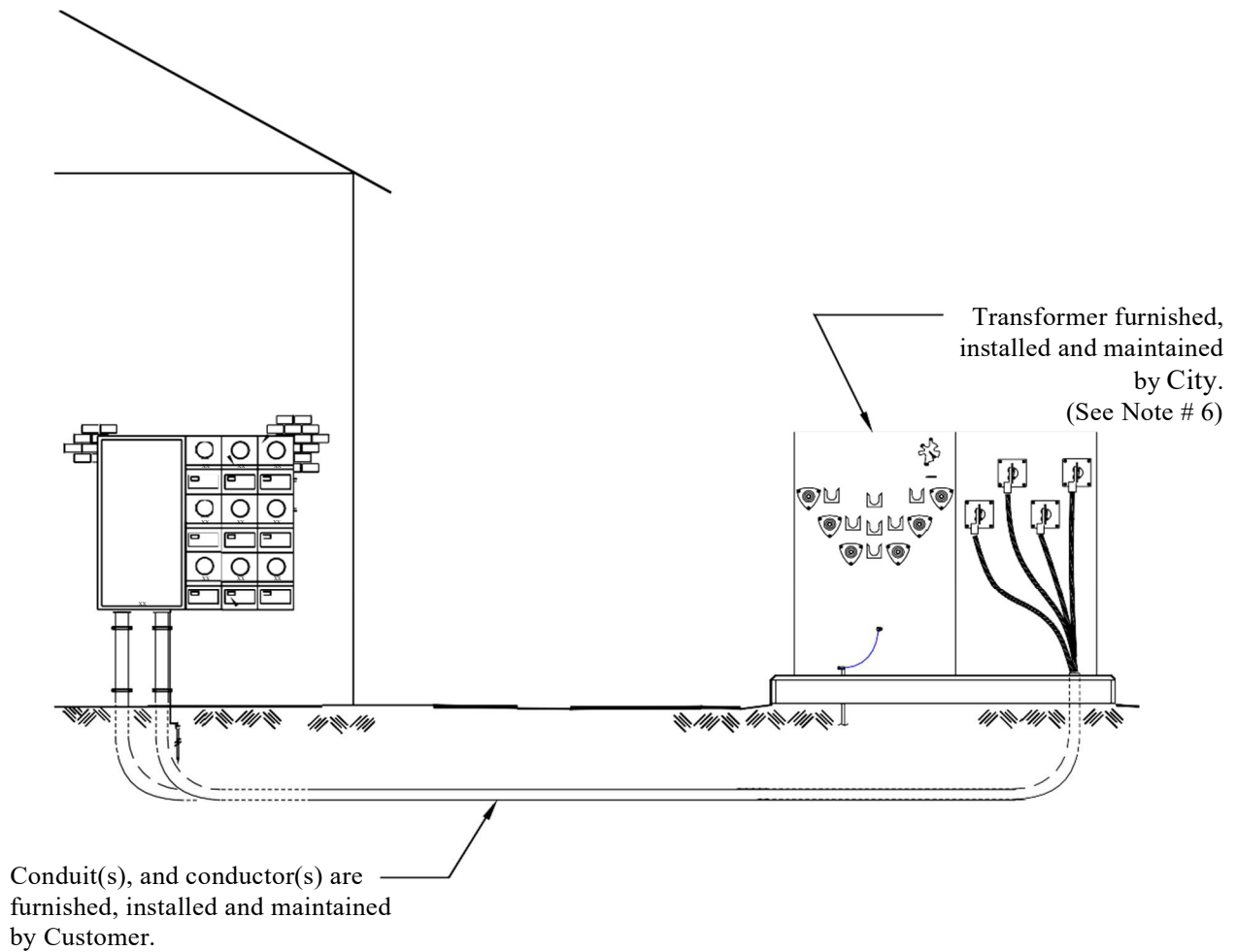

ALTERNATIVE UNDERGROUND MULTI-METERED SERVICE USING A METER CENTER AND A TERMINATION ENCLOSURE

NOTES:

- 1) City -approved Meter center furnished and installed and maintained by Customer.
- 2) Meter centers with ring-type design shall be supplied by Customer with screw-type rings approved by City.
- 3) Line-side disconnect with overcurrent device is required.
- 4) Load-side service disconnects and overcurrent devices are required.
- 5) All connections in the Termination Enclosure will be made by the Customer.
- 6) All connections in the transformer will be made by City.

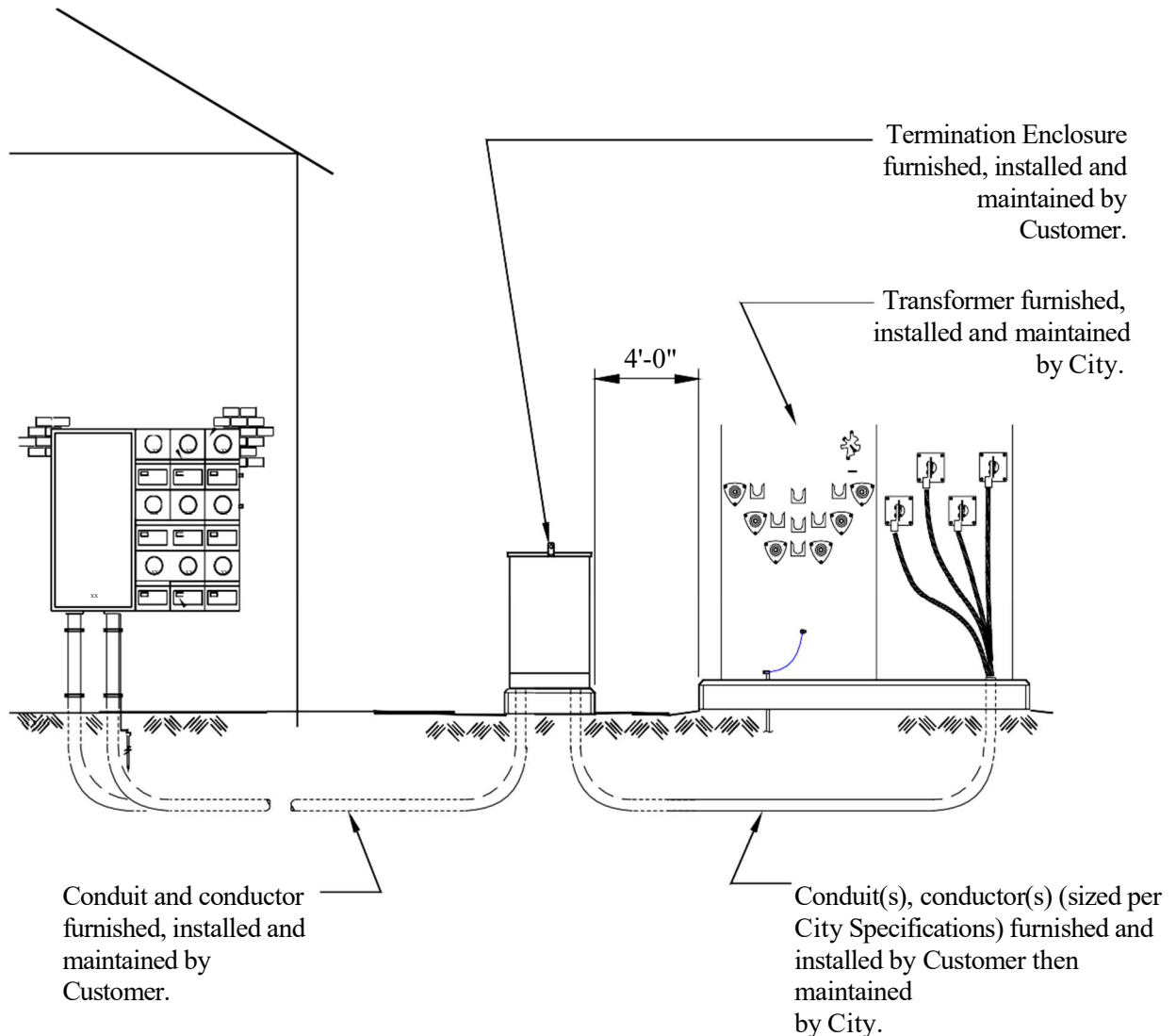

**This Application must be Approved by the
City Electric Department**

2.0 GENERAL CUSTOMER INFORMATION 2.1 APPLYING FOR SERVICE,
DEPOSITS

- A. The following items shall be completed by the Customer in order to activate the electricity account:
1. Completion in person of an application for electric service, with the service address clearly identified.
 2. Payment of all applicable deposits (or acceptable letter of credit) and fees.
 3. Obtainment of applicable permits and certificates of occupancy.
 4. Compliance with any applicable ordinances.

2.2 REQUIRED INFORMATION

- A. The Customer shall supply to the City a description of new installations in order for the City to determine the type and method of service the Customer may qualify for. At minimum, the following items shall be furnished for each new commercial, industrial, and multi-family residential installation: This information shall be given to the City Planning and Zoning Department during the site plan review process. This office will coordinate with the Electric Department.
1. Site Plan: The site plan shall show, in addition to other required information, location of main disconnect(s), desired electrical service location(s), and desired location(s) for City electrical equipment.
 2. Electrical Plan: One complete set of electrical plans shall be furnished for each proposed service, including a panel schedule, and indicating the size(s) of heating and air conditioning loads.
 3. Electrical Load Calculation: One electrical total connected load calculation shall be furnished for each proposed service.
- B. For 120/240 volt, single-phase, single-family residential services up to 200 amps, the information noted on the electrical permit will generally be sufficient to enable the City to determine service requirements. The Customer shall contact the City to determine service location.

2.3 CUSTOMER EQUIPMENT

- A. All wiring and electrical equipment of the Customer shall be installed according to this policy manual and in compliance with requirements of the City Building Department and the latest edition of the NEC and NESC, as well as guidelines of other local inspection authorities. All wiring installations must be inspected and approved by an authorized electrical inspector as required by law. The Customer is cautioned against the purchase and use of electrical equipment that is not approved by competent authority. Compliance of Customer-owned facilities with the requirements of the NEC will provide the Customer with a safe installation, but not necessarily an efficient or convenient installation. For this reason, the requirements for service listed herein may exceed those required by the NEC. Frequently, a larger service entrance, a higher point of attachment, more branch circuits, or types of service equipment that exceed code minimums are desirable. As a general convenience, the electrical contractor shall

provide a stencil (decal) or tag with their name, address, and phone number on the service switch of the Customer's wiring system.

- B. Each facility served by the City shall have the facility's assigned street address number permanently attached to the structure in compliance with the specifications of the City Code of Ordinances or any other applicable application. The Customer is required to post the address before electrical service will be connected. The Customer shall permanently maintain the numbers. These numbers shall be attached to a residence or commercial building.

2.4 TEMPORARY SERVICE

- A. Applications for temporary service shall be made well in advance of the required service date. Temporary service locations shall be clearly marked with the lot number and street address shown on the application. Temporary services shall comply with all requirements applicable to permanent services, i.e., application for service, code compliance, inspection by local authorities, etc.
- B. Temporary service installations shall be constructed with the same care as permanent service installations. Where practical, overhead temporary service shall be located near the permanent service location to allow relocation without splicing the conductors. Standard Overhead temporary service shall be located within 80 feet of an existing pole. Standard Temporary service location served from underground distribution shall be located within three feet (3') of a pad-mount transformer, Underground Distribution (UD) Service Enclosure or other location designated by the City.

2.5 CUSTOMER ALTERATIONS OR ADDITIONS

- A. The Customer shall notify the City before adding any significant load (i.e. 20%). Relocation of the point of Service Location must also be approved by the City before construction may begin. The Customer shall provide information for the proposed alterations or additions.

2.6 STANDBY AND PARALLEL GENERATION

- A. Improperly installed generation equipment can create serious hazards for City Customers, personnel, and equipment. For that reason, Customer-owned generators must be installed correctly.
 - 1. Standby generators shall be installed in compliance with the NEC and local codes. They shall be properly connected through transfer switches so they are completely isolated from the City system. The Customer shall submit to the City a complete manufacturer's description of the transfer switch along with a power distribution diagram showing the connection of the switch into the Customer's internal wiring system. Customer failure to provide and maintain a City-approved transfer switch on the Customer's standby generator constitutes a safety hazard and shall be grounds for disconnection of electrical service.

2. Generators designed to run in parallel with the City's system require special protective devices, and shall not be permitted to back-feed into the distribution system. Contact the City for specific protective requirements for the proposed facility. The Customer should be aware that parallel generation also requires the monthly application of charges by the City for providing standby service.

3.0 DESIGN REQUIREMENTS

3.1 TEMPORARY SERVICE

- A. Temporary service is available for construction, fairs, exhibits, and other similar temporary purposes. The term of temporary service shall not exceed one year.
- B. Temporary Service board shall be furnished, installed, and maintained by the Customer, on a pole of appropriate length and strength. Temporary service installation shall be inspected and approved by the appropriate electrical inspector prior to rendering of service. Meter socket, ground rod and grounding conductor in accordance with NEC shall also be supplied by the Customer.
 1. Temporary service boards served overhead shall be located in areas specified and approved by the City. These facilities shall be constructed to conform to the minimum clearances required by NESC and these clearances must be maintained as long as temporary service is provided.
 2. Temporary service boards served underground shall be located in area approved by the City.
- C. Interconnection between a temporary service and a permanent meter socket or with the Customer's permanent breaker panel or other permanent electrical equipment is prohibited except during test purposes.

3.2 OVERHEAD SERVICE

- A. Customers shall confirm availability of service and obtain an approved meter location before beginning construction. Meters shall be located on the front half of the side of the building that is closest to the City service facilities. Meter location that may at some point become un-accessible (such as fenced rear or side yards) is to be avoided. Typical City service facilities are located in front of building.
- B. The point of delivery between City's service drop and the Customer's service entrance will be designated by the City after consultation with the Customer, but is typically at the weatherhead connection. All clearances for the point of delivery must comply with the NESC and NEC.
 1. When necessary to install a service mast to obtain the clearance required, the mast shall not be less than 2-inch trade size rigid galvanized steel conduit. A service mast exceeding three feet in height above the roof or last means of support shall be adequately guyed to withstand the strain imposed by the service drop. The service mast shall be designed to support a minimum working load of 500 pounds.
 2. The Customer shall furnish all hardware necessary for attaching the service drop to a building, including 2-inch minimum conduit, conduit straps, meter socket, and ground rod and grounding conductor in accordance with NEC.

The Customer is responsible for installing the hardware in a secure manner using a through-bolt attached to a structural member. The service attachment hardware shall be designed to support a minimum-working load of 500 pounds.

- C. Service conduits shall be continuous from the weatherhead to the meter socket or disconnecting device; whichever is appropriate for the installation. Maintenance of the weatherhead and/or the mast extension is the responsibility of the Customer.
- D. Service conductors shall comply with NEC as required by the inspection authority having jurisdiction. All service conductors located on the same point of service shall be made of the same conductive material (aluminum or copper). These conductors shall extend a minimum of three feet beyond the weatherhead to allow connection by the City.
 - 1. Conductors carrying unmeted energy shall not be contained in the same raceway or conduit with conductors carrying metered energy.
 - 2. For safety reasons, the grounded conductor of the service cable shall be plainly marked with white phase tape at the weatherhead and the meter socket unless the conductor insulation is white or gray.
- E. For proper metering of four-wire, three-phase delta service, the phase having the highest voltage to ground (high leg) must be maintained in the right hand or “C” phase position in the meter socket. To insure proper connections, the high leg must be plainly marked with orange tape at the weatherhead and inside the meter socket.
- F. For service equipment rated larger than 400 amps (nominal rating), the service conductors shall be installed underground.
- G. The maximum span length of service conductor that the City will install is determined by the characteristics of the load to be served. If necessary to maintain minimum clearance, the City may install one pole on the Customer’s property at no additional expense to the Customer. Under no circumstances will service conductor attachments be made to trees.

3.3 UNDERGROUND SERVICE

A. Residential

- 1. Customers shall confirm availability of underground service and obtain an approved meter location before beginning construction. Meters shall be located on the front half of the side of the building that is closest to the City service facilities. Meter location that may at some point become un-accessible (such as fenced rear or side yards) is to be avoided. Typical City service facilities are located in front of building.
- 2. The point of delivery between the City Distribution System and the Customer’s facilities will be determined by the City after consultation with the Customer. The Customer is responsible for furnishing and installing all conduit, concrete equipment foundations and related civil infrastructure. The City will furnish and install service conductors for a detached single-family residential service.
- 3. The Customer shall locate load-side conduit on right side of the meter socket and line-side conduit on the left. The Customer shall furnish and install service

conduits to service pedestal or transformer. The meter socket, conduit, straps, conduit elbow, and ground rod and grounding conductor in accordance with NEC shall be furnished and installed by the Customer.

4. Metering equipment shall be located outside and accessible to employees of the City. Meter sockets and enclosures shall not be mounted in or on City pad-mount transformers.

B. Commercial

1. Customers shall confirm availability of underground service and obtain an approved meter location before beginning construction. Meters shall be located on the side of the property closest to the City service facilities. Meter location that may at some point become un-accessible is to be avoided. Typical City service facilities are located on the street side of building.
2. The point of delivery between City Distribution System and the Customer's facilities will be determined by the City after consultation with the Customer. The Customer is responsible for the pad-mounted transformer, furnishing and installing all conduit, concrete equipment foundations and related civil infrastructure. The Customer shall furnish and install service conductors and conduit for all multi-position multi-meter installations, commercial services, and all other services (except detached single family residential service). Service laterals, conduit and accessories shall be furnished and installed by the Customer and Ownership shall remain with the Customer upon connection of service.
3. The Customer shall locate load-side conduit on right side of the meter socket and line-side conduit on the left. The Customer shall furnish and install service conduits to service pedestal or transformer. The meter socket, conduit, straps, conduit elbow, and ground rod and grounding conductor in accordance with NEC shall be furnished and installed by the Customer.
4. The largest three-phase, pad-mount transformer offered for 120/208 volt service is 500 kva. The largest three-phase, pad-mount transformer offered for 277/480volt service is 2500 kva. Where circumstances require more capacity than can be supplied by one transformer, the Customer shall contact the City as soon as possible. The final connection of service conductors will be made at the transformer by the City.
5. Metering equipment shall be located outside and accessible to qualified employees of the City. Meter sockets and enclosures shall not be mounted in or on pad-mount transformers. Specialized metering equipment requirements shall be approved by the City in advance.

3.4 SERVICE IN NEW DEVELOPMENT

- A. Multi-family buildings of three or more units, subdivisions of three or more units, or any tract of land that will be developed into apartments or divided as a subdivision, commercial or industrial development shall be considered a "new development".
- B. In the case of a new development requesting overhead or underground electrical service, as part of the site plan or preliminary plat process, the Developer shall submit to the City's Office of Planning and Zoning final design plans including but not limited to, the

following items:

1. Property boundary lines including individual lot or parcel lines inside the property
 2. Topographic lines
 3. Easements to be dedicated
 4. Paved Areas (i.e., streets with center lines, parking and similar areas)
 5. Trees and other landscaping
 6. Drainage (i.e., storm drains, retention areas)
 7. Legal property description including copy of the plat, location sketch, right-of-way lines, Point of Commencement, Point of Beginning, adjoining properties with building/ structure outlines and dimensions
- C. The size and number of Customer or Developer-installed service conductors that can be connected to a single pad-mount transformer is limited. Therefore it is essential that the Developer/Customer consult the City well in advance of construction to avoid unnecessary delays.
- D. Utility Trenches
1. The Developer is responsible for the final clearing and grading of all public utilities easements and public right-of-ways prior to the installation of electric facilities. All surveying, plan location staking and grade determination for utilities are the responsibility of the Developer. The Developer shall keep all utility easements clear of construction materials, dirt piles, and any other debris at all times.
 2. The Customer or Developer shall be responsible for excavation, backfill and final grade for all trenches, including the proper installation of all conduit required.
 3. All underground primary, secondary and service conductors shall be installed in a continuous conduit system. The conduit system, concrete equipment foundations, and related infrastructure will be as specified by the City, and shall be furnished and installed by the Customer. Ownership of the conduit system shall transfer to the City upon acceptance.
- E. Primary Installations
1. The City will work with the Owner or Developer and their electrical engineer for the design of an economical underground distribution (UD) system that is compatible with existing and planned facilities. The location of all equipment including transformers, switchgear, sectionalization cabinets, UD service enclosures, UD junction box, and meters will be specified as part of the underground electric system design.
 - a. The City will designate the location of pad-mounted transformers, the route of primary voltage conductor laterals, and the location of primary voltage switchgear for all developments.
 2. The City will procure, install, and maintain all primary conductors, transformers, switchgear, and related equipment required to render service to a development as provided in these requirements.

- a. The City will make all primary and secondary electrical connections and terminations within equipment it maintains.

F. Equipment Installations

1. The Customer or Developer is responsible for providing the service entrance equipment and conduit for all detached single-family services. The City will furnish the service conductors to the meter, for detached single-family residents only.
2. Service conductors installed by the Customer or Developer shall be of sufficient length to allow at minimum a five-foot tail to permit the electrical connection to the pad-mount transformer, or other equipment.
3. Ownership of any Developer-installed conduit system, excluding commercial service laterals and conduits, shall be transferred to the City upon acceptance of electrical service.
4. Underground commercial services that originate from an overhead source shall be furnished and installed by the Customer or Developer up to the base of the pole. The Customer or Developer shall furnish the City with sufficient conductors and other materials required to make-up the permanent electrical connections. The Customer or Developer is responsible for providing the service entrance equipment including the service conductors and conduit for all commercial and multi-unit buildings.
5. The City will make final determination as to the type, size and location of all metering installations.

3.5 RESPONSIBILITY FOR FURNISHING AND INSTALLING UNDERGROUND INFRASTRUCTURE

- A. Where underground distribution facilities are required by governmental regulations, prudent utility practice, or are requested by the Customer or Developer, City will install underground distribution facilities at the Customer's or Developer's cost provided that the Customer or Developer furnishes and installs all conduit, concrete equipment foundations and related civil infrastructure as directed by City.
- B. The Customer or Developer shall be responsible for the excavation, backfill and final grade of all trenches, including the proper installation of all conduit required (conduit to be supplied by the Customer or Developer).
- C. The Customer or Developer is responsible for providing the service entrance equipment including the service conductors, conduit(s) and termination enclosures if needed, for all commercial and multi-unit buildings. These facilities shall be owned and maintained by the Owner.
- D. The Customer or Developer is responsible for providing the service entrance equipment and conduit (conduit shall be installed with one piece of continuous pre-lubricated woven polyester pull tape with printed sequential footage markings) for all detached single family services. City will furnish the service conductors in the Customer's conduit from the transformer or underground enclosure to the meter socket (point of delivery), for detached single family residences only. Ownership of

any Developer-installed conduit system for a detached single family residential service will be transferred to City upon acceptance.

1. The detached single family service and secondary conduit shall be sized in accordance with Table 1.
- E. At Developer’s cost, City will furnish, install, and maintain all primary conductors, transformers, switchgear, and related equipment required to render service to a development as provided in these requirements.
- F. City will make all primary and secondary/service electrical connections and terminations within transformers and underground enclosures.
- G. The City Electric Department will make the final determination as to type, size and location of all metering installations.
- H. The size and number of Customer or Developer-installed service conductors that can be connected to one pad-mounted transformer is limited. Therefore it is essential that the Developer/Customer consult the Electrical Department well in advance of construction to avoid unnecessary construction delays. The cost of all remedial work shall be borne exclusively by the Customer.
- I. Service conductors installed by the Customer or Developer shall be of sufficient length to allow at minimum a five (5) foot-tail to permit the electrical connection to the pad-mounted transformer, or other equipment.
- J. For underground non-residential commercial services that originate from an overhead secondary source, the Customer shall furnish and install the conduits, conductors and underground enclosure from the Customer’s equipment to the Customer-installed underground enclosure at the base of the pole. City will make the connections in the underground enclosure and will take over Ownership and maintenance of the underground enclosure upon acceptance. The Customer or Developer shall furnish City with a sufficient length of conductor and other materials required to make the permanent electrical connections.

Table 1: Conduit Sizes for Underground Secondary Cable

NOMINAL SIZE CODE WORD	CABLE DIAMETER	WEIGHT LBS. PER 1000'	CONDUIT SIZE (PVC)
6/3	0.648"	135	1-1/2"
1/0-1/0-2 Brenau	1.106"	387	2-1/2"
4/0-4/0-2/0 Sweetbriar	1.421"	709	2-1/2"
350-350-4/0 Wesleyan	1.795"	1118	3"
500-500-300 Brooklyn	2.065"	1544	3"
4/0-4/0-4/0-2/0 Wake Forest	1.588"	993	3"
350-350-350-4/0 Slippery Rock	2.006"	1582	4"

500-500-500-350 Wafford	2.363"	2231	4"
----------------------------	--------	------	----

4.0 METERING

4.1 TYPE

A. The metering equipment will measure the electrical power flowing through the service of each account in the units of measure as required by the appropriate City rate schedule.

1. In order to meter the electrical power consumed by the Customer, the City will measure both the current flowing to the Customer and the voltage level at which that current is flowing. Normally, the City will meter single- and three-phase, secondary services of 200 amps and below using self-contained meters. Secondary services between 200 and 400 amps may be metered with a self-contained meter, depending upon the nature of the Customer's facility and load. The City will make the decision on whether to install instrument transformers in place of a self-contained meter.
 - a. When self-contained meters are used, the Customer's service entrance is connected directly into the meter socket. The line voltage is applied to the meter and full load currents flow through the meter.
 - b. On all self-contained installations where the service voltage is 277/480 volts, a non-automatic disconnect device shall be furnished and installed by the Customer on the line side of each individual meter, including the connection between the disconnect device and meter. The disconnect device shall be adjacent to the respective meter. The disconnect device ampacity shall be equal to or greater than the Customer's main breaker capacity. Ownership of the disconnect device shall transfer to the City upon connection of service.
2. Secondary services above 400 amps and all primary services require instrument transformers to transform line currents (and voltages for primary service) to measurable magnitudes. The input to output ratio for current transformers (CTs) used on both primary and secondary services is determined by the magnitude of the current flow at Customer peak load. The ratio of the potential transformers (PT) used on the primary services is determined by the primary service voltage.

4.2 MATERIALS

- A. The City will provide the meter for each Customer's electrical service. Only City-owned meters may be installed.
- B. City-approved meter sockets (single-phase or three-phase as appropriate) shall be furnished, installed and maintained by the Customer. As an exception, where CT metering will be installed, the City will furnish a three-phase meter base with safety test blocks for installation by the Customer. The City will furnish, install and maintain the required meters, metering devices, and secondary wiring between the instrument transformers, meters and metering devices.
1. Metering equipment furnished by the City for Customer installation shall be obtained from the City by presenting a copy of the Electrical Permit issued by the local inspection authority. No equipment will be issued after the expiration date of the permit or after permanent power has been installed.

4.3 METER LOCATION

- A. Meter locations must be approved by the City. Meters shall be installed outdoors and shall be readily accessible to the City at all times. If the meter ever becomes inaccessible due to locked doors, fences or other obstacles, the Customer shall be required to move the meter or perform other changes in order to make the meter accessible again.
- B. Metering equipment shall be surface mounted, and shall be located to provide unobstructed working space per the NEC. The Customer shall provide for the secure installation of City-metering equipment. Instrument transformer cabinets shall be secured against unauthorized access. Door and/or removable cover allowing access to the instrument transformers shall be equipped with a means to allow the installation of lock and/or seal by the City.
- C. In cases where the City makes the decision to install secondary CTs on underground pad-mounted transformer bushings, the Customer shall install the meter can on a 6"x6"x8' concrete post set not less than 2 feet into the final grade. The meter can shall be in close proximity to the pad-mounted transformer. The City must approve the location of the meter post. The Customer shall furnish and install a one-inch PVC conduit raceway between the transformer and the meter post for CT secondaries.
- D. Meters installed on the driveway or parking lot side of a structure shall have a minimum four-foot lateral clearance from the meter to the parking or driving surface unless the meter is protected by a permanent part of the structure or by guard structures. Guard structures shall be constructed from six-inch diameter by eight-foot long galvanized steel pipe mounted in concrete and filled with concrete. The pipe shall be mounted four feet below grade with four feet extending above grade. The above grade portion of the pipe shall be painted yellow. Guard structures, minimum two required, shall be installed four feet in front of the meters and four feet on centers to protect all exposed meters.
- E. Upon Customer request, the City may permit the use of meter rooms in multi-occupancy buildings of three stories or more in height. Prior to beginning construction, the Customer shall provide the City with two copies of plans for approval. Meters shall not be installed without City authorization.

4.4 PRIMARY METERING

- A. Service at primary distribution voltage is subject to special negotiations between the Customer and the City since the facilities for such service require special materials and engineering consideration. It is always advisable to consult the City in advance of the time such service will be required so design and construction can be properly coordinated.
- B. Primary voltage service for large power Customers will be supplied at 7.2/12.47 kV provided that a 400 kW demand will be realized and this voltage is available at the Customer's location.
- C. Primary voltage service will be supplied from the nearest suitable facility. The Customer shall furnish and install any necessary transformer installations, and shall retain Ownership and responsibility for maintenance of these facilities.

1. The Customer's loads shall be balanced as equally as possible among the three phases to minimize the impact of the service on the City's primary distribution system.
- D. Primary voltage service shall incorporate Customer-furnished and -installed over-current protective device(s) to isolate the Customer from the City's service facilities during fault or excessive load conditions on the Customer's service. The interrupting capacity of all protective devices shall be rated to exceed the fault current available at the Customer's location as determined by the City. The City will approve the protective device prior to installation. The physical point of installation will be designated by the City, in consultation with the Customer, typically near the point of delivery.

4.5 CURRENT TRANSFORMER (CT) METERING

- A. Current transformers (CTs) in the Customer's service entrance will be installed in a City-approved enclosure. The enclosure will be either the pad-mounted transformer cabinet or a City-furnished CT cabinet. CTs shall be located ahead of all loads, and no Customer wiring or equipment shall be permitted in the CT enclosure except the Customer's service entrance.
1. CTs will be furnished and installed by the City, securely mounted within the enclosure. The secondary terminal compartment of each CT shall be readily accessible and the nameplate data of each CT shall be visible without disturbing the Customer's service entrance. The base of each CT will be solidly grounded.
 2. Provision shall be made for City connection of potential leads to the meters. When CTs are installed on a bus bar type service entrance, the Customer shall drill and tap a 1/4 x 20 hole in one bus bar per phase. The hole shall be located on the line side of the CT. The Customer shall provide a 1/4 x 20 machine screw of the proper length for each hole. The screw shall be of an appropriate metal to avoid reaction with the bus material.
- B. The Customer shall mark service entrance conduits entering the CT cabinet either "LINE" for conduits from the City's source side or "LOAD" for conduits to the Customer's service equipment.

4.6 MULTIPLE INSTALLATIONS

- A. The Customer may furnish and install one multiple position meter socket per building. The socket shall have no more than five positions, each rated 200 amperes (nominal), or less. Multiple position meter socket shall not be installed where the fault current at the meter socket exceeds 10,000 amperes.
- B. Customer-furnished meter centers are required for all multi-unit buildings that do not qualify for a multiple position meter socket. The Customer shall furnish and install all conduit and service conductors. Terminal lugs shall accept cables up to 350 kcmil. Meter centers shall have line and/or load side disconnecting means with over-current protection. Meter centers shall be equipped with ring type meter sealing rings. Sealing rings shall be good quality screw type rings approved by the City.

TYPICAL THREE-PHASE, PADMOUNT TRANSFORMER, TRANSFORMER RATED METERING INSTALLATION SERVING ONE CUSTOMER

NOTES:

- 1) Customer may be required to install CT's in a separate compartment at City's option.
- 2) Socket and conduit shall be grounded at the transformer ground.
- 3) Metering conduit risers located in areas subject to physical damage, as determined by a qualified City employee, shall be rigid steel.

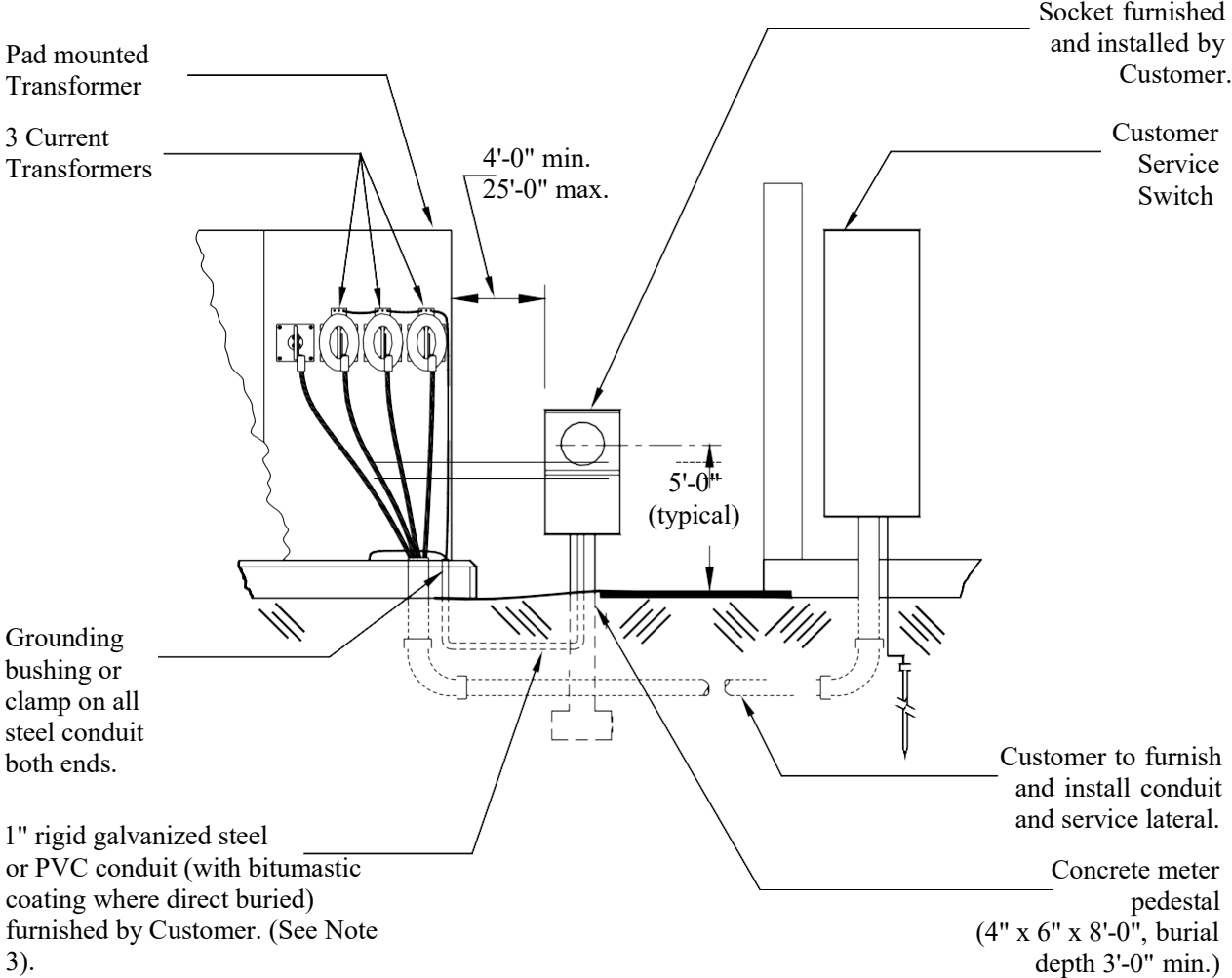

This Application must be Approved by the City of Alachua Electric Department

1. On multi-unit buildings where meter centers are utilized, the meter centers shall be arranged into one assembly with one point of service.
- C. On multi-unit buildings where a wiring trough is utilized to serve more than one Customer, a line side over-current device is required. A load-side disconnecting means is also required for each tenant. The disconnecting means shall be readily accessible to City personnel and shall accept a City lock.
- D. Where a single transformer serves more than one building, each meter shall have a load-side disconnecting means with over-current protection located adjacent to the meter socket and accessible to City personnel.
- E. To minimize cross-metering and avoid delays in providing service to multi-unit facilities, the buildings, entrances to individual units, and meter sockets served shall be labeled.
 1. The building (address) identification shall be firmly affixed to the front of the building or to a separate structure in front of the building (such as a mailbox, post, wall, fence, etc.). The identification marking shall be displayed in a manner such that they are clearly visible and legible from the public or private roadway on which the building fronts.
 2. The individual unit (i.e., apartment number) identification shall be firmly affixed and centered on the entrance door of the unit or centered immediately above the door frame if room permits, and shall be clearly visible and legible.
 3. Identification on the apartment building shall be a minimum of three- inches (3") high and one-half inch (1/2") wide, and identification on the individual units shall be a minimum of two-inches (2") high and one-quarter inch (1/4") wide. The identification shall be of a contrasting color with the immediate background of the building or structure on which such markings are affixed.
 4. Each meter socket enclosure and cover shall be permanently identified with the corresponding building and individual unit number that the meter serves. Identification inside the meter socket enclosures and outside the meter socket covers shall be marked with no less than one-quarter inch (1/4") high stamped lettering. Wood, metal, or plastic labels firmly attached by means of rivets are also allowed.
 5. Facilities not in compliance with the above guidelines during meter socket and wiring inspection will result in an automatic inspection failure and delays in meter installations.

4.7 MOBILE HOME METERING

A. Underground Installations

1. Meter poles or pedestals shall be furnished for mobile homes to be served by underground distribution, for the connection of service laterals and mounting of watt-hour meters.
2. Meter pedestals shall be approved by the City before being installed. The City does not assume Ownership of meter poles or pedestals and is not responsible for maintenance.

3. Grounding shall be in compliance with the NEC and all local codes.

4.8 METER ACCURACY TESTING

A. The City will make every effort practical to maintain the standard accuracy of City metering installations. Customer request for meter tests and information concerning billing adjustments shall be made through City's Utility Billing Department. If a Customer requests a meter to be tested and the test shows the metering equipment to be within acceptable accuracy limits, a charge may be assessed against the Customer if the previous Customer-requested test was within 12 months of this test. Charges and billing adjustments will be made in accordance with the latest City policy.

1. If, upon test, any metering equipment is found to be in error by not more than two percent, previous recordings of the metering equipment shall be considered accurate, and will be used by the City in computing the Customer's billing for service under the applicable rate schedule.

2. If, upon test, any metering equipment is found to be in error by more than two percent, all previous recordings by such equipment shall be corrected for the error for a period not to exceed 12 months.

5.0 LIGHTING SERVICES

5.1 PUBLIC LIGHTING

A. Public lighting is streetlight on any public right of way or public property that is sponsored by a public agency. The City will provide this type of lighting upon written authorization from the City, County, or State agency having jurisdiction in accordance with the applicable lighting guidelines of the respective agency.

B. The City will provide technical assistance and cost estimates to the requesting agency for all proposed street area lighting and installations.

C. The City provides standard types and sizes of street and area luminaries including poles in accordance with local code.

D. The City will bill the appropriate agencies monthly for each streetlight in accordance with applicable filed rates. If any agencies request additional lighting, the City will bill for additional lighting requested.

5.2 STREET LIGHTING FOR NEW DEVELOPMENTS

A. Streetlights required.

1. The Developer of any property within the City shall be responsible for the installation of street lighting on all private, city, county, and state roads, both internal to the development at the time the development is subdivided into individual lots or at the time of semi-permanent inspection.

B. Responsibility of the Developer.

1. The Developer shall provide plans for the development sufficiently in advance of construction to permit the street lighting system to be designed and installed at the same time other overhead or underground electric facilities are required to be

installed.

2. The Developer shall be responsible for informing the City of any desired deviation from the City's standard street lighting system.

6.0 DEFINITIONS

Alternating Current (AC) - Current that reverses at regular intervals of time, with alternately positive and negative values. The period of alternation is one cycle, and standard frequency in the U.S. is 60 cycles per second (60 hertz).

Ampere- The unit of measurement of electric current.

Billing Demand- The peak 15-minute integrated power demand for a particular billing period expressed in kilowatts (kW).

Bus (Busbar) - An electrical conductor or electrically conducting bar that serves as a common connection for two or more electrical circuits.

Cable- An electrical conductor with insulation, or a combination of two or more separately insulated conductors banded or twisted together.

Capacitor- An electrical device used to improve the power factor of electrical loads, or to improve the voltage profile of power lines, and thus increase the efficiency of the electrical system by offsetting inductive losses that produce wasted energy.

Circuit- A conductor or system of conductors connected to equipment at both ends, through which electric current flows or is intended to flow.

City- City of Alachua, Florida.

COA- City of Alachua, Florida.

Commercial Service- The type of service available to Customers engaged in a business, professional or social activity.

Conduit- A tubular duct, used to carry one or more cables.

Contributions-in-Aid-of-Construction (CIAC) - The cost to be paid by the Customer that is in excess of the normal amount spent by the City to extend service to a Customer.

Current- The volume of electricity flowing through a conductor, expressed in amperes (amps or A).

Customer- Any individual, developer, Owner, partnership, corporation, agency, trustee or any present or prospective user of electric service provided by the City, or their authorized representative. A Customer may have more than one account.

Delta Connection- A three-phase electrical connection where the windings of equipment (transformers, load, etc.) are connected in a closed series, without a neutral connection.

Demand- The magnitude of electrical load at a given time at an installation. Demand is typically expressed in kilowatts (kW) or Kilovolt-amperes (kva).

Developer- Any person or legal entity with Ownership or control of a development or site with requirements for electric service facilities.

Distribution- Delivery of electric energy to Customers on the distribution system. Delivery is accomplished over primary distribution lines, through a distribution transformer(s) and over secondary service cables.

Distribution System- All materials and equipment utilized by the City to provide electricity to Customers throughout its service territory: the electricity supply system.

Energy- Electric power consumed over time, typically expressed in kilowatt-hours (kWh).

Easement- A portion of a privately owned parcel of land that is dedicated by the Owner for the primary purpose of installing, maintaining, and replacing utilities.

Feeder (Distribution)- The main trunk line from which taps carry electricity to Customers.

Final Grade- Ground level after all construction and landscaping has been completed.

Grounded- Connected to earth potential through a low impedance connection, to prevent the buildup of hazardous voltages.

Grounded Conductor- A system or circuit conductor that is intentionally grounded.

High Leg- The conductor in a three-phase delta secondary connection that has a higher voltage-to-ground potential than the other conductors.

Inspector- Person or agency authorized to inspect and approve electrical installations.

Kilowatt (KW)- 1000 watts. A watt is the unit of measurement of electrical power or rate of doing work.

Line Side- The side of a device toward the source of electric power.

Load- The Customer's equipment requiring electrical power. Or, the quantity of electric power required by the Customer's equipment, usually expressed in kilowatts (kW) or horsepower (Hp).

Load Side- The side of a device toward the consumer of electric power.

National Electrical Code- The minimum standard for electrical installations, as enacted by the National Fire Protection Association and adopted and enforced by local inspection authorities.

National Electrical Safety Code- The minimum standard for electric utility installations, as enacted by the American National Standards Institute and the Institute of Electrical and Electronics Engineers.

Overhead Service- Wiring and associated facilities normally installed on poles by the City to serve the Customer from a distribution transformer(s).

Pad-Mounted Transformer- A distribution transformer located at ground level, normally on a concrete pad.

Point of Attachment- That location at which the City attaches its service to the wiring system installed by the Customer.

Point of Delivery- The point where the City's facilities are connected to the service cable serving the Customer, i.e., at the Customer's weatherhead (overhead service) or at the load side meter lugs (underground service).

Primary Service Voltage- The City's distribution system voltage level. For service taken at primary voltage all additional transformations shall be Customer-owned.

Raceway- A mechanical structure for supporting wiring, conduit or bus.

Rate Schedule- The approved standard used for monthly calculation of bills.

Right-of-Way- Land in which a public roadway and permitted utilities are installed.

Secondary Voltage- The voltage level at the load side of a distribution transformer(s) or secondary pedestal, and at which the Customer receives service.

Secondary Pedestal- Above grade junction box where secondary cables terminate and services are started.

Semi-Permanent Inspection- The point in time when temporary electric service is made permanent on a residential or commercial structure.

Service Conductors- The conductors and equipment used to deliver energy from the electric supply system to the wiring system of the premises served, and/or the wires or cables installed and maintained by the City to deliver electricity from the City's distribution system to the point of delivery.

Service Drop- The overhead service conductors from the last pole or other aerial support to and including the splices, if any, connecting to the service entrance conductors at the building.

Service Entrance- The portion of the wiring system between the point of attachment to the distribution system and the load-side terminals of the Customer's main switch or switches, including the grounding equipment.

Service Equipment- The necessary equipment, usually consisting of circuit- breaker or switch and fuses, and their accessories, located near the point of entrance of supply conductors to a building and intended to constitute the main control and means of disconnection for the supply to that building.

Service Lateral- The underground service conductor(s) between the transformer, handhole, connection cabinet or pole and the Customer's terminal box, meter socket, or other enclosure.

Service Location- The point established by the City for the location of the service entrance (the location of the meter).

Sub-Meter or Test Meter- A meter used to check electric usage on a particular electrical load for a non-billing purpose.

Tap- An electric circuit with limited capacity extending from the main feeder, usually supplying a small number of Customers.

Temporary Service- Service that is provided by the City for limited time use, such as construction purposes.

Transformer- A device used to transmit power by electromagnetic induction to effect a difference in operating voltage levels.

Voltage- The electrical potential or pressure of a circuit, expressed in volts (V).

Weatherhead- A device used at the service entrance to prevent water from entering the service mast or riser.

Wye Connection- A three-phase electrical connection where the windings of equipment (transformer, load, etc.) are connected to a common neutral point in a “Y” configuration.

7.0 EXHIBITS

EXHIBIT 7.1: TABLE OF AVAILABLE FAULT CURRENT (NOTES 1, 2)

KVA	TYPE	PHASE	VOLTAGE	% Z Min. - Max.	BASIS OF DESIGN SHORT CIRCUIT AMPERES (SCA)	
37.5	Pole/Pad	1	120/240	1.5 - 3.00	10,417	SCA
50	Pole/Pad	1	120/240	1.5 - 3.00	13,889	SCA
75	Pole/Pad/ Submersible	1	120/240	1.5 - 3.00	20,833	SCA
100	Pole/Pad/ Submersible	1	120/240	1.6 - 3.00	26,042	SCA
167	Pole/Pad	1	120/240	1.6 - 3.00	43,490	SCA
250	Pole	1	120/240	5.0 - 5.75	20,833	SCA
3 - 25	Pole	3	208Y/120	1.5 - 3.00	13,889	SCA
3 - 37.5	Pole	3	208Y/120	1.5 - 3.00	20,833	SCA
3 - 50	Pole	3	208Y/120	1.5 - 3.00	27,778	SCA
3 - 75	Pole	3	208Y/120	1.5 - 3.00	41,667	SCA
3 - 100	Pole	3	208Y/120	1.6 - 3.00	55,536	SCA
3 - 167	Pole	3	208Y/120	1.6 - 3.00	86,750	SCA
3 - 50	Pole	3	480Y/277	1.5 - 3.00	12,034	SCA
3 - 75	Pole	3	480Y/277	1.5 - 3.00	18,051	SCA
3 - 100	Pole	3	480Y/277	1.6 - 3.00	22,563	SCA
3 - 167	Pole	3	480Y/277	1.6 - 3.00	37,681	SCA
75	Pad	3	208Y/120	1.4 - 5.00	14,881	SCA
112.5	Pad	3	208Y/120	1.4 - 5.00	22,321	SCA
150	Pad	3	208Y/120	1.4 - 5.00	29,762	SCA
225	Pad	3	208Y/120	1.4 - 5.00	44,643	SCA
300	Pad	3	208Y/120	1.4 - 5.00	59,524	SCA
500	Pad	3	208Y/120	1.4 - 5.00	99,206	SCA
750	Pad	3	208Y/120	5.32 - 5.75	39,160	SCA
1000	Pad	3	208Y/120	5.32 - 5.75	52,214	SCA
75	Pad	3	480Y/277	1.4 - 5.00	6,447	SCA
112.5	Pad	3	480Y/277	1.4 - 5.00	9,670	SCA
150	Pad	3	480Y/277	1.4 - 5.00	12,893	SCA
225	Pad	3	480Y/277	1.4 - 5.00	19,340	SCA
300	Pad	3	480Y/277	1.4 - 5.00	25,786	SCA
500	Pad	3	480Y/277	1.4 - 5.00	42,977	SCA
750	Pad	3	480Y/277	5.32 - 5.75	16,965	SCA
1000	Pad	3	480Y/277	5.32 - 5.75	22,620	SCA
1500	Pad	3	480Y/277	5.32 - 5.75	33,930	SCA
2000	Pad	3	480Y/277	5.32 - 5.75	45,239	SCA
2500	Pad	3	480Y/277	5.32 - 5.75	56,549	SCA

Notes:

1. Available at secondary terminals based on unlimited source.
2. Consult with COA for specific job application.