

124 WATER MAIN REDUCTION OF LINE SIZE
NTS

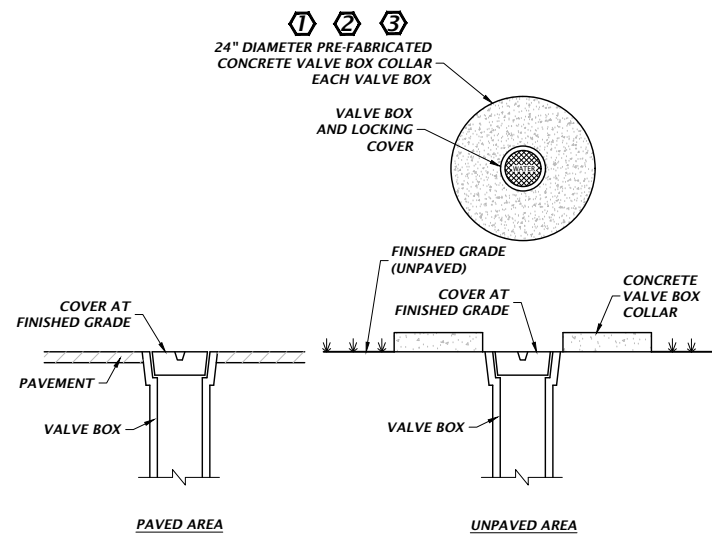

- KEYED NOTE(S):**
- ① VALVE BOX COLLAR FEATURES:
 - 24" DIAMETER, 11" INNER OPENING
 - 4" THICK
 - TWO RINGS OF #3 REBAR
 - ② SUPPLIER AND PRODUCT:
 - MASONRY SUPPLY, INC., SELMA, NC OR EQUAL
 - ITEM: 24" CONCRETE VALVE BOX COLLAR OR EQUAL
 - PART: MSVB-24 OR EQUAL
 - ③ PAINT VALVE BOX COVER AND COLLAR AS PER **307**

127 VALVE BOX COVER
NTS

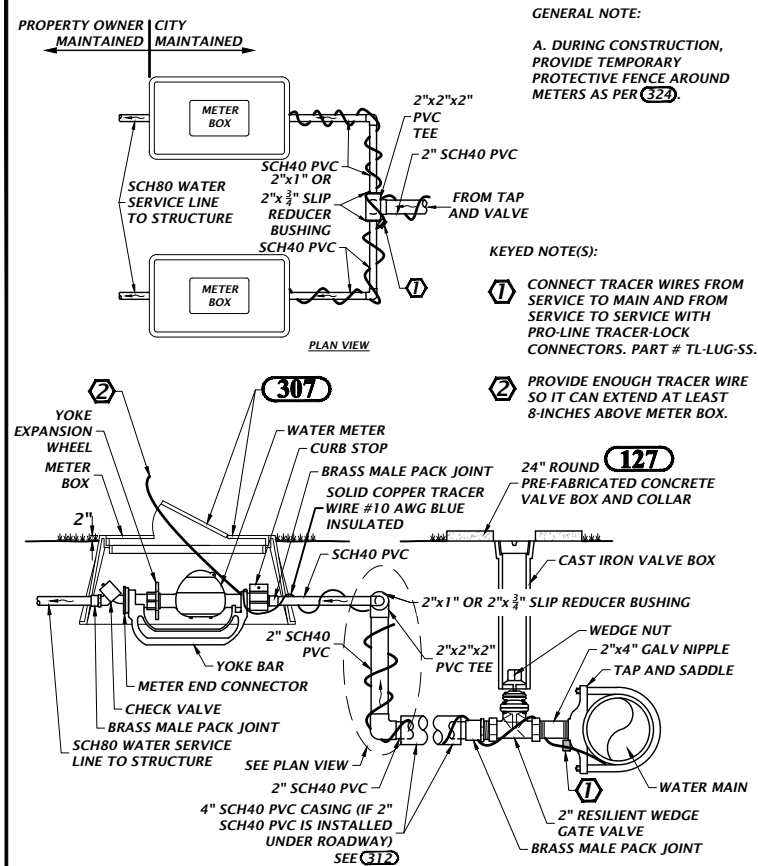

130 DUAL WATER SERVICE CONNECTION
NTS

ABBREVIATIONS

APP	APPROXIMATE
ARV	AIR RELEASE VALVE
AWG	AMERICAN WIRE GAUGE
DI	DUCTILE IRON
DIP	DUCTILE IRON PIPE
E	ELECTRIC CONDUCTOR
FLG	FLANGED
FT	FOOT
FM	FORCE MAIN
GA	GAUGE
GALV	GALVANIZED
GRN	GREEN
GSP	GALVANIZED STEEL PIPE
GV	GATE VALVE
ID	INSIDE DIAMETER
LF	LINEAR FEET
MAX	MAXIMUM
MIN	MINIMUM
MJ	MECHANICAL JOINT
NTS	NOT TO SCALE
OD	OUTSIDE DIAMETER
OS&Y	OUTSIDE SCREW AND YOKE
PUE	PUBLIC UTILITY EASEMENT
PVC	POLYVINYL CHLORIDE
R/W	RIGHT OF WAY
RPZ	REDUCED PRESSURE ZONE
SCH	SCHEDULE
SF	SQUARE FEET
SIM	SIMILAR
SS	STAINLESS STEEL
TYP	TYPICAL
URD	UNDERGROUND RESIDENTIAL DISTRIBUTION
YEL	YELLOW
WM	WATER MAIN
WW	WASTEWATER

151 DETAIL ABBREVIATIONS
NTS

MATERIALS

ITEM	QUANT.	DESCRIPTION
1	1	ENCLOSURE, WATER PLUS CORPORATION MODEL #131632
2	1	AIR RELEASE VALVE 2" NPT, ARI MODEL D-040 FOR WATER OR RECLAIMED WATER.
3	1	1" CURB STOP, S.S.
4	1	2" x 4" NIPPLE, S.S.
5	1	2" BALL VALVE, PVC OR SST (WITH SST HANDLE AND SST NUTS)
6	1	2" TEE, S.S.
7	1	2" x 1" REDUCER, S.S.
8	1	1" SHORT NIPPLE, S.S.
9		NOT USED
10		NOT USED
11		NOT USED
12	1	2" DOUBLE STRAP TAPPING SADDLE, STAINLESS STEEL
13	1	4" & LARGER PIPE, D.I. OR PVC (DR-18)
14	1	AMERICAN MODEL 4001 2" SST FLANGED BALL VALVE WITH GEAR OPERATOR, 90° WITH 2" OPERATING NUT
15	2	1-1/2" PIPE, PVC, LENGTH AS REQUIRED
16	1	1-1/2" x 90° ELBOW, PVC

- GENERAL NOTE(S):**
1. AIR RELEASE VALVES 2" IN DIAMETER SHALL BE USED ON 4" THROUGH 16" DIAMETER WATER OR RECLAIMED MAINS.
- KEYED NOTE(S):**
- ① ENCLOSURE SHALL BE COLOR CODED BLUE FOR POTABLE WATER AND PURPLE FOR RECLAIMED WATER.
 - ② CONNECT TRACER WIRES FROM MAIN TO SERVICE WITH PRO-LINE TRACER-LOCK CONNECTORS. PART # TL-LUG-SS.
 - ③ PROVIDE ENOUGH TRACER WIRE SO IT CAN EXTEND AT LEAST 8-INCHES ABOVE GRADE.

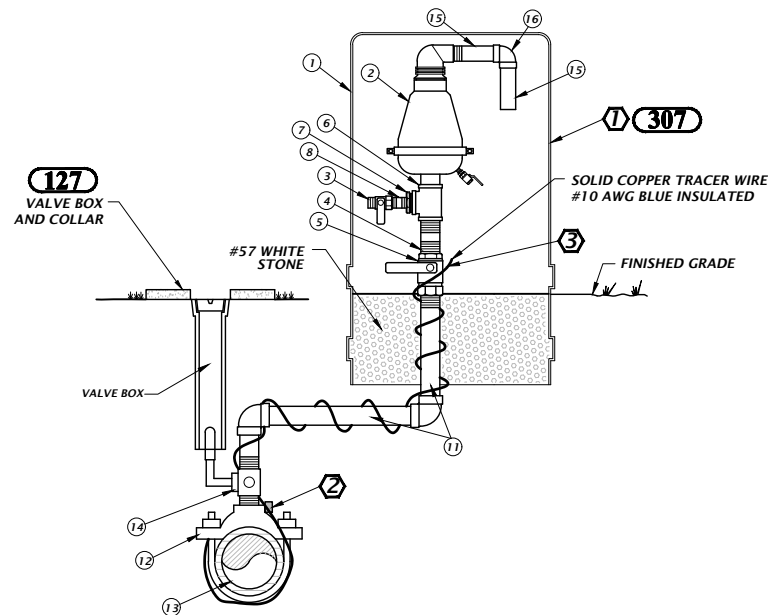

133 POTABLE WATER OR RECLAIMED AIR RELEASE VALVE
NTS

METER SIZE	DIMENSION		
	①	②	③
4"	24"	12"	14"
6"	36"	18"	18"
8"	48"	24"	22"
10"	60"	30"	27"

- GENERAL NOTE(S):**
1. PROVIDE FREEZE PROTECTION BOX AS FOLLOWS:
 - CORRUGATED ALUMINUM EXTERIOR WITH INTERIOR INSULATION
 - EASY INTERNAL ACCESS FOR TESTING AND MAINTENANCE. PROVIDE CLASPS OR EQUIVALENT.
 - BOX SHALL COVER BOTH WATER METER AND BYPASS LINE SEGMENTS.

- KEYED NOTE(S):**
- ① DIMENSION AA MUST BE MINIMUM 5 TIMES PIPE DIAMETER (UPSTREAM OF METER).
 - ② DIMENSION BB MUST BE MINIMUM 3 TIME PIPE DIAMETER (DOWNSTREAM OF METER).
 - ③ WATER METER AND STRAINER FURNISHED, OWNED, AND MAINTAINED BY COA.
 - ④ VALVE BOX SERVES AS ACCESS POINT FOR TRACER WIRE. PROVIDE ENOUGH LOOPED TRACER WIRE SO IT CAN EXTEND AT LEAST 8-INCHES ABOVE VALVE BOX.
 - ⑤ BACKFLOW PREVENTER FURNISHED, INSTALLED AND MAINTAINED BY PROPERTY OWNER, NOT COA.
 - ⑥ IF REQUIRED BY ALACHUA COUNTY FIRE RESUCE (ACFR) REPLACE ELBOW WITH TEE AND FDC HOSE CONNECTIONS

136 FIRE LINE 4" AND LARGER WATER METER AND BACKFLOW PREVENTER ASSEMBLY
(WITH DOWNSTREAM DIESEL FIRE PUMP OR PRIVATE FIRE PROTECTION SYSTEM)
NTS

