

CUT TO LENGTH SPOOL PIECE WITH HARNESS LUGS, MANUFACTURED FLANGE ON UPSTREAM END, AND MEGAFLANGE RESTRAINED FLANGE ADAPTER ON DOWNSTREAM END.

3/4" DETECTOR CHECK VALVE

3/4" SHUTOFF VALVE VALVE AND DETECTION BYPASS METER

PLAN VIEW

GENERAL NOTE(S):

1. PROVIDE FREEZE PROTECTION BOX AS FOLLOWS:
 - CORRUGATED ALUMINUM EXTERIOR WITH INTERIOR INSULATION
 - EASY INTERNAL ACCESS FOR TESTING AND MAINTENANCE. PROVIDE CLASPS OR EQUIVALENT.
2. BOX SHALL COVER BOTH WATER METER AND BYPASS LINE SEGMENTS.

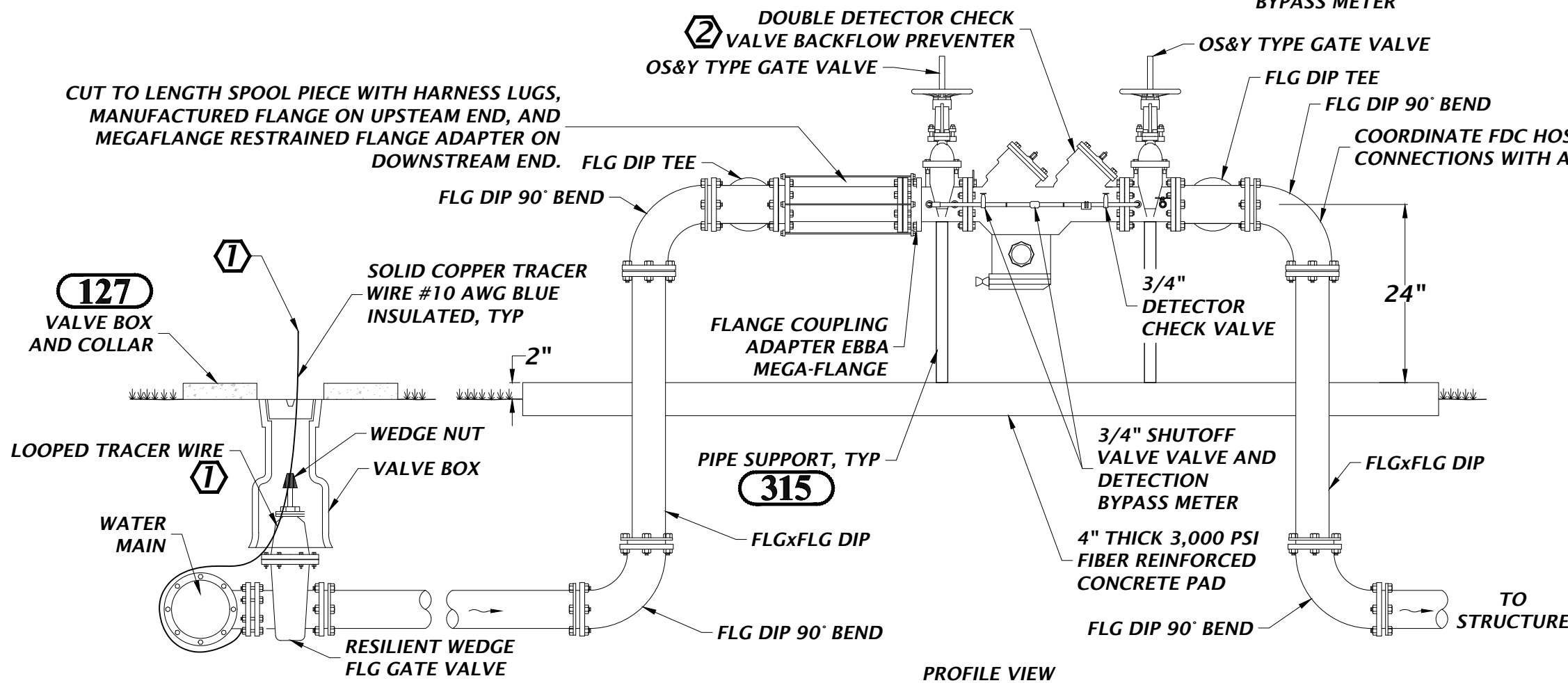

KEYED NOTE:

- ① VALVE BOX SERVES AS ACCESS POINT FOR TRACER WIRES. PROVIDE ENOUGH LOOPEd TRACER WIRE SO IT CAN EXTEND 8-INCHES ABOVE VALVE BOX.
- ② BACKFLOW PREVENTER FURNISHED, INSTALLED AND MAINTAINED BY PROPERTY OWNER, NOT COA.
- ③ IF REQUIRED BY ALACHUA COUNTY FIRE RESCUE (ACFR), REPLACE ELBOW WITH TEE AND FDC HOSE CONNECTIONS.

FIRE LINE 4" AND LARGER DOUBLE DETECTOR CHECK VALVE BACKFLOW PREVENTER (NO DOWNSTREAM DIESEL FIRE PUMP)

NTS