

** REFER TO CURB NOTES

TYPE 'B' CONCRETE CURB

NTS

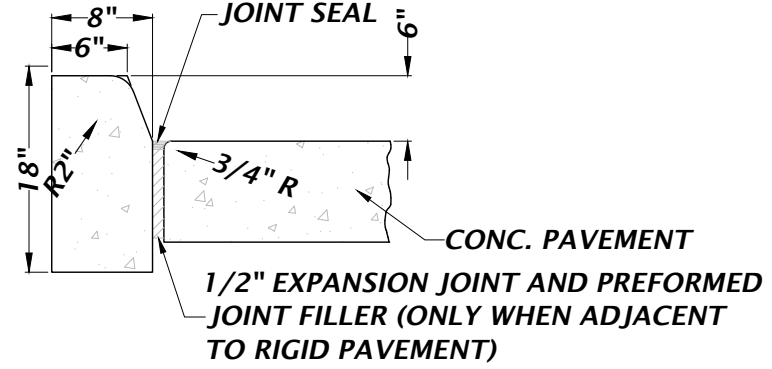

** REFER TO CURB NOTES

TYPE 'D' CONCRETE CURB

NTS

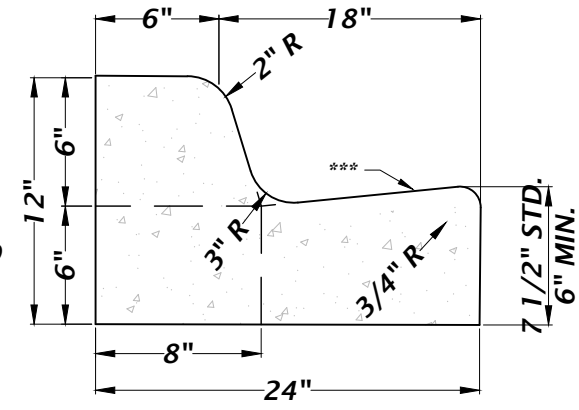

TYPE 'F' CONCRETE CURB AND GUTTER

NTS

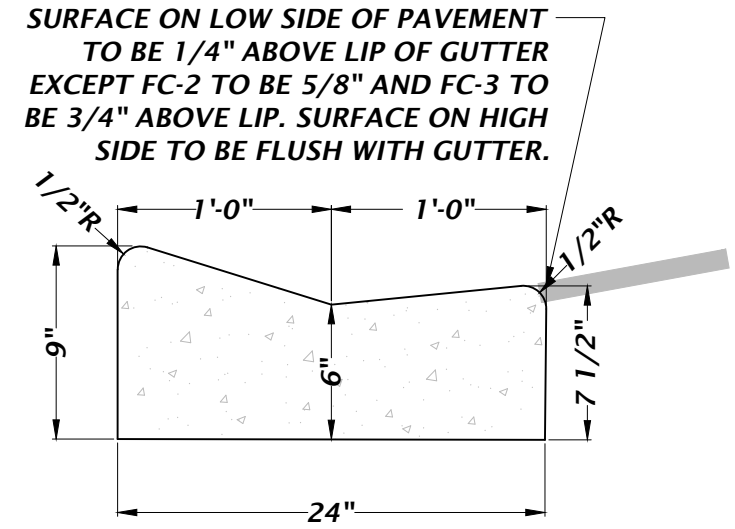

TYPE 'MIAMI' CURB & GUTTER

NTS

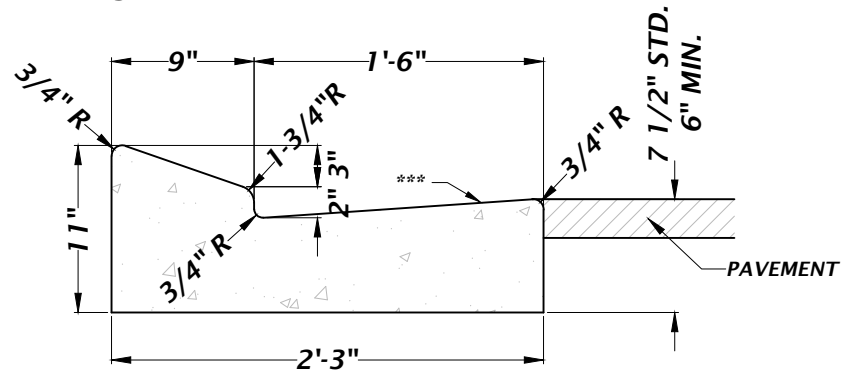

TYPE 'E' CONCRETE CURB AND GUTTER

NTS

- ** CURB NOTES**
- FOR CURB, GUTTER, CURB AND GUTTER AND TRAFFIC SEPARATORS PROVIDE 1/8" - 1/4" CONTRACTION JOINTS AT 10' CENTERS (MAX.). CONTRACTION JOINTS ADJACENT TO CONCRETE PAVEMENT ON TANGENTS AND FLAT CURVES ARE TO MATCH THE PAVEMENT JOINTS, WITH INTERMEDIATE JOINTS NOT TO EXCEED 10' CENTERS.
 - ENDS OF CURBING SHALL TRANSITION FROM FULL TO ZERO HEIGHTS IN 3 FEET.

***** GUTTER SLOPE NOTE:**
WHEN USED ON THE HIGH SIDE OF ROADWAY, THE CROSS-SLOPE OF THE GUTTER SHALL MATCH THE CROSS-SLOPE OF THE ADJACENT PAVEMENT AND THE THICKNESS OF THE LIP SHALL BE 6".

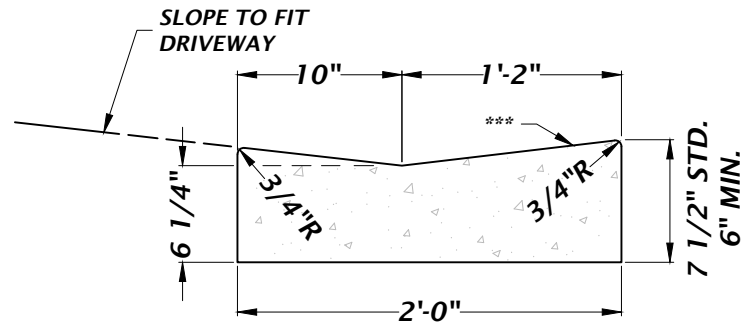

DROP CURB

NTS

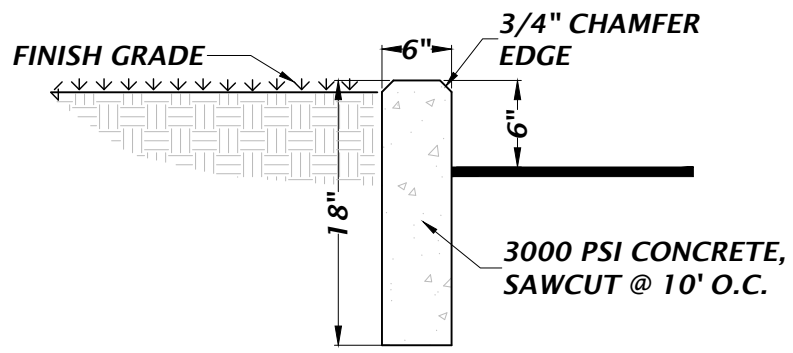

TYPICAL 6" CURB DETAIL

NTS

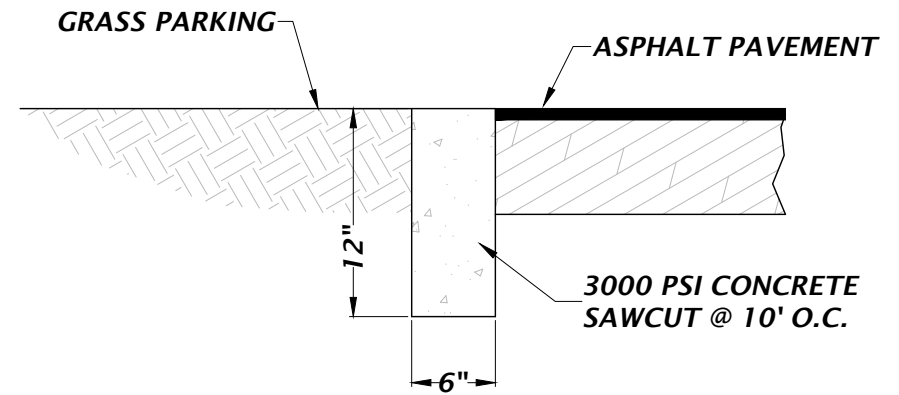

FLUSH CURB

NTS