

GENERAL NOTE(S) :

- 1) ALL CONDUIT FURNISHED AND INSTALLED BY OWNER. CONDUIT SHALL BE INSTALLED WITH ONE PIECE OF CONTINUOUS PRE-LUBRICATED WOVEN POLYESTER PULL TAPE WITH PRINTED SEQUENTIAL FOOTAGE MARKINGS.
- 2) THIS 48" X 52" (NOTE LOCATION OF FUSE AND SWITCH SIDES OF SWITCHGEAR) AREA WILL BE LOCATED IN THE FIELD AND USED TO INSTALL CONDUIT BEFORE THE CONCRETE BOX IS INSTALLED.
- 3) DO NOT CUT OFF ELBOWS.
- 4) FOR 4" CONDUIT A 48" RADIUS ELBOW IS REQUIRED. FOR LESS THAN 4" CONDUIT, 36" RADIUS ELBOW IS REQUIRED.

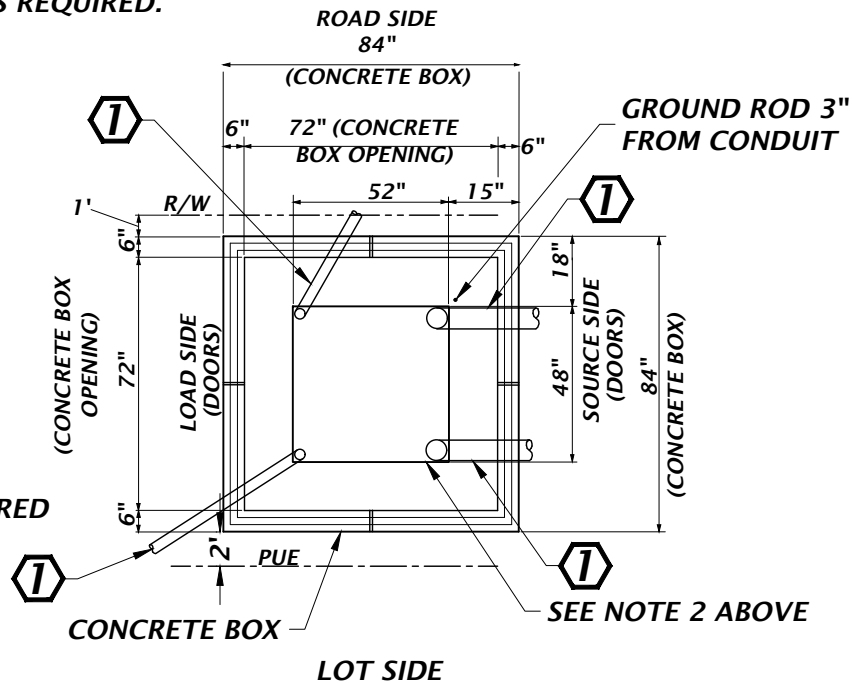

KEY NOTE(S)

1 CONDUCTORS, CONDUIT AND ROUTING AS REQUIRED

SEE NOTE 2 ABOVE

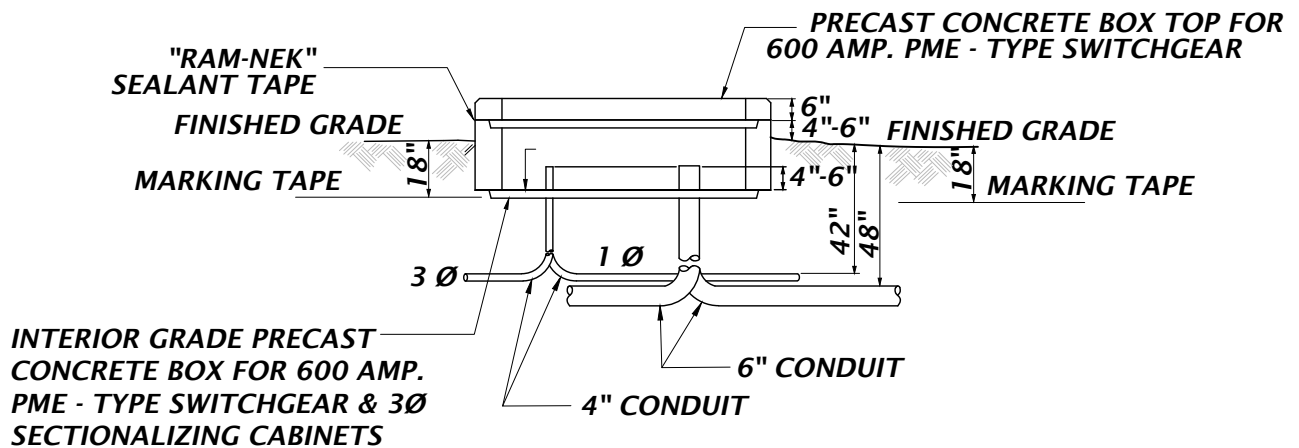

518

**TYPICAL 600 AMP. PME 9 & SOURCE TRANSFER
PME 9, SWITCHGEAR AND SECTIONALIZING
CABINET (SC) & 3Ø CONDUIT LAYOUT**

NTS

