

**GENERAL NOTE(S):**

- 1) **DO NOT CUT OFF ELBOWS. ELBOWS AT EQUIPMENT LOCATIONS AND THE CONDUIT SYSTEM TRANSITION TO THIS EQUIPMENT WILL BE INSTALLED DEEPER THAN THE NOMINAL INSTALLATION DEPTH TO MEET TURN-UP REQUIREMENTS. ELBOWS SHALL BE TURNED UP IN CENTER PORTION OF BASE.**
- 2) **2" OR 4" CONDUIT SHALL BE USED AS SHOWN ON THE SITE PLAN.**
- 3) **PROVIDE THREE 4-WAY JUNCTION BARS AT ALL LOCATIONS. GROUND PER NATIONAL ELECTRICAL SAFETY CODE.**
- 4) **FOR 4" AND 6" CONDUIT, 48" RADIUS ELBOWS ARE REQUIRED; FOR LESS THAN 4" CONDUIT 36" RADIUS ELBOWS ARE REQUIRED**
- 5) **CABINET MADE BY COA - APPROVED MANUFACTURER.**

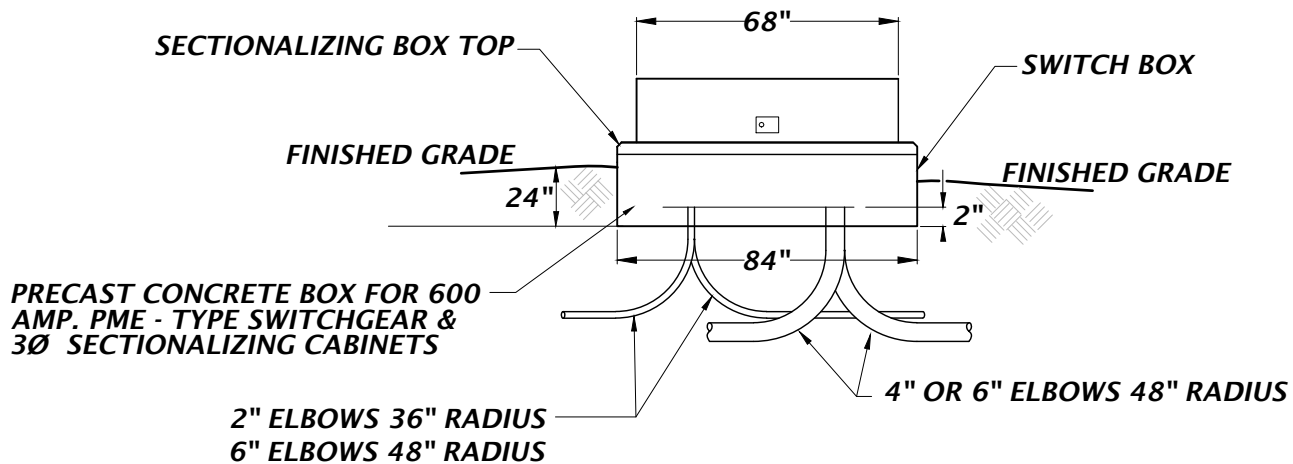

**TYPICAL SECTIONALIZING CABINET (SC)  
WITH SECTIONALIZING BOX TOP AND  
SWITCH BOX**

**NTS**

**527**